

Haier

Multi-Zone Ductless Multi-Split Heat Pumps



2U18MS2HDA
3U24MS2HDA



4U36MS2HDA



5U42MS2HDA



Wall Mount - Highwall

- AW07TC2HDA
- AW09TC2HDA
- AW12TC2HDA
- AW18TC2HDA
- AW24TC2HDA



Mid-Static Ducted

- USYM09UCDSA
- USYM12UCDSA
- USYM18UCDSA
- USYM24UCDSA



2'x2' Compact Cassette

- AB09SC2VHA
- AB12SC2VHA
- AB18SC2VHA



Console

- USYF09UCDWA
- USYF12UCDWA
- USYF18UCDWA



TABLE OF CONTENTS

1. SPECIFICATIONS.....	3	6. FLOOR CONSOLE INDOOR UNITS	25
2. SYSTEM.....	6	6.1 Dimensions.....	25
2.1 General.....	6	6.2 General.....	26
2.2 Performance and Operating Range.....	6	6.3 Installation	26
2.3 Combination Tables	6	6.4 Electrical Requirements.....	26
2.4 Installation Requirements	14	6.5 Components.....	27
2.5 Electrical Requirements.....	14	7. COMPACT CASSETTE INDOOR UNITS.....	28
3. OUTDOOR UNITS	15	7.1 Dimensions.....	28
3.1 Dimensions.....	15	7.2 General.....	28
3.2 General.....	16	7.3 Installation	29
3.3 Installation	16	7.4 Electrical Requirements.....	29
3.4 Components.....	17	7.5 Components.....	29
4. HIGHWALL INDOOR UNITS.....	18	7.6 Panel.....	30
4.1 Dimensions.....	18	8. CONTROLS AND ACCESSORIES	31
4.2 General.....	18	8.1 Wireless Control.....	31
4.3 Installation	19	8.2 Wired Controllers	31
4.4 Electrical Requirements.....	19	8.3 WiFi.....	32
4.5 Components.....	19	8.4 WK-B Interface Kit	32
5. MID-STATIC DUCTED INDOOR UNITS.....	21	9. LIMITED WARRANTY.....	33
5.1 Dimensions.....	21		
5.2 General.....	23		
5.3 Installation	23		
5.4 Electrical Requirements.....	23		
5.5 Components.....	24		

Revision History

05/01- Edition release.

1. SPECIFICATIONS



Compressor Type:
DC Inverter Driven Rotary

Voltage/Cycle/Phase:
208-230/60/1



		2U18MS2HDA	3U24MS2HDA	4U36MS2HDA	5U42MS2HDA
	UPC	084691876526	084691876540	084691876564	084691910053
Cooling Non-Ducted	Rated Capacity Btu/hr	18,000	22,600	34,000	41,000
	Capacity Range Btu/hr	4,500 - 19,500	5,000 - 24,000	10,000 - 37,000	10,000 - 42,500
	SEER2	21.0	22.0	19.0	18.0
	EER2	12.7	12.8	9.0	7.8
Cooling Ducted	Rated Capacity Btu/hr	18,000	22,600	34,000	41,000
	Capacity Range Btu/hr	5,000 - 20,000	5,000 - 24,000	10,000 - 37,000	10,000 - 42,500
	SEER2	18.0	16.0	16.0	14.8
	EER2	11.2	11.0	8.8	7.2
Heating Non-Ducted	Heating Capacity Range Btu/hr	3,000 - 22,000	4,000 - 26,000	6,500 - 38,000	7,000 - 43,000
	Rated Heating Capacity 47°F Btu/hr	21,000	25,000	36,000	42,000
	Max. Heating Capacity 5°F Btu/hr	10,800	10,000	22,600	26,000
	COP @ 5°F / @ 47°F	1.58/3.52	1.8/3.66	1.75/3.35	1.9/3.40
	Heating Capacity -4°F Btu/hr	11,400	12,000	18,000	22,000
	HSPF2 (IV)/HSPF2 (V)	10.0/7.5	10.0/7.5	9.4/7.0	8.8/6.7
Heating Ducted	Heating Capacity Range Btu/hr	3,000 - 20,000	4,000 - 26,000	6,500 - 38,000	7,000 - 43,000
	Rated Heating Capacity 47°F Btu/hr	19,000	25,000	36,000	42,500
	Max. Heating Capacity 5°F Btu/hr	11,300	12,500	21,000	27,000
	COP @ 5°F / @ 47°F	1.46/3.52	1.80/3.41	1.80/3.15	1.9/3.56
	Heating Capacity -4°F Btu/hr	9,200	11,000	17,000	22,000
	HSPF2 (IV)/HSPF2 (V)	8.5/6.5	9.0/6.8	8.4/6.6	8.8/6.9
Operating Range	Cooling °F (°C)*	14~115°F (-10~46°C)	14~115°F (-10~46°C)	14~115°F (-10~46°C)	14~115°F (-10~46°C)
	Heating °F (°C)	-4~75°F (-20~24°C)	-4~75°F (-20~24°C)	-4~75°F (-20~24°C)	-15~75°F (-26~24°C)
Power Supply	Wire Size between ID and OD	14/4 AWG Stranded	14/4 AWG Stranded	14/4 AWG Stranded	14/4 AWG Stranded
	Maximum Fuse Size A	30	30	30	40
	Minimum Circuit Amp A	19	22	26	33
	Outdoor Fan Speed RPM	300~700	300~700	300~880	300~880
Outdoor Unit	Outdoor Noise Level dB	51	53	58	63
	Dimension: H x W x D in (mm)	27 5/8 x 35 1/2 x 13 1/2 (700 x 900 x 346)	27 5/8 x 35 1/2 x 13 1/2 (700 x 900 x 346)	33 1/8 x 37 3/8 x 13 1/2 (840 x 948 x 340)	38 x 37 1/2 x 14 5/8 (965 x 950 x 370)
	Carton Dimension: H x W x D in (mm)	31 1/8 x 39 3/8 x 17 1/2 (790 x 998 x 443)	31 1/8 x 39 3/8 x 17 1/2 (790 x 998 x 443)	41 3/8 x 41 3/4 x 16 1/2 (1048 x 1060 x 420)	46 1/8 x 41 3/8 x 19 1/8 (1170 x 1050 x 485)
	Weight Ship/Net - lbs (kg)	130/115 (59/52)	132/117 (60/53)	194.5/161 (88.2/73)	218/181 (99/82.2)
	Connectable Indoor Unit Quantity	2	2 or 3	2, 3 or 4	2, 3, 4 or 5
	Base Pan Heater	No	No	No	Standard
Refrigerant Lines	Connections	Flare	Flare	Flare	Flare
	Liquid O.D. in	1/4 1/4	1/4 1/4 1/4	1/4 1/4 1/4 1/4	1/4 1/4 1/4 1/4 1/4
	Suction O.D. in	3/8 3/8	3/8 3/8 3/8	3/8 3/8 3/8 1/2	3/8 3/8 3/8 1/2 1/2
	Factory Charge Oz	60.0	67.0	90.0	113.0
	Maximum Line Length Ft/m	98/30	197/60	230/70	262/80
	Maximum Height Ft/m	50/15	50/15	50/15	50/15
	Minimum Line Length for each individual indoor unit Ft / m	10/3	10/3	10/3	10/3
	Maximum Line Length for each individual indoor unit Ft / m	66/20	82/25	82/25	82/25
	Maximum Line Length without additional charge Ft / m	50/15	98/30	131/40	164/50

*Cooling below 23°F (-5°C) requires wind baffle.

2 CAPACITY CORRECTION:

- Please refer to the submittal documents for specific Capacity Correction tables available at www.GEAppliancesAirAndWater.com

1. SPECIFICATIONS

Highwall Indoor



	AW07TC2HDA	AW09TC2HDA	AW12TC2HDA	AW18TC2HDA	AW24TC2HDA
UPC	084691885917	084691885924	084691885931	084691895251	084691885948
Rated Cooling Capacity Btu/hr	7,000	9,000	12,000	18,000	22,000
Rated Heating Capacity Btu/hr	8,000	10,000	13,000	19,000	24,000
Voltage, Cycle, Phase V/Hz/Phase	208-230/60/1	208-230/60/1	208-230/60/1	208-230/60/1	208-230/60/1
Cooling Airflow CFM (Turbo/High/Med/Low/Quiet)	400/315/274/222/187	421/332/292/242/200	426/360/310/265/200	596/532/478/422/340	846/744/668/592/482
Heating Airflow CFM (Turbo/High/Med/Low/Quiet)	387/302/241/198/156	397/310/250/211/165	404/320/274/229/166	596/506/451/399/318	846/707/631/560/451
Cooling Motor Speed RPM (Turbo/High/Med/Low/Quiet)	1210/1010/910/810/730	1250/1050/950/850/750	1250/1100/1000/900/750	1300/1150/1050/950/800	1300/1150/1050/950/800
Heating Motor Speed RPM (Turbo/High/Med/Low/Quiet)	1170/950/850/750/680	1200/970/870/770/700	1200/1020/920/820/700	1300/1100/1000/900/750	1300/1100/1000/900/750
Indoor Sound dB (Turbo/High/Med/Low/Quiet)	42/36/33/29/26	42/36/33/29/26	42/38/34/31/26	48/45/42/39/36	50/47/44/41/38
Dimension: H x W x D in (mm)	11 7/8 x 33 3/4 x 7 3/4 (301 x 856 x 196)	11 7/8 x 33 3/4 x 7 3/4 (301 x 856 x 196)	11 7/8 x 33 3/4 x 7 3/4 (301 x 856 x 196)	12 7/8 x 39 3/8 x 8 3/4 (327 x 999 x 223)	13 1/4 x 43 7/8 x 9 (337 x 1115 x 230)
Carton Dimension: H x W x D in (mm)	14 3/4 x 36 7/8 x 10 1/2 (374 x 937 x 265)	14 3/4 x 36 7/8 x 10 1/2 (374 x 937 x 265)	14 3/4 x 36 7/8 x 10 1/2 (374 x 937 x 265)	16 x 42 3/4 x 11 5/8 (405 x 1085 x 296)	16 1/2 x 46 3/4 x 11 3/4 (417 x 1187 x 301)
Weight Ship/Net - lbs (kg)	26.9/21.2 (12.2/9.6)	26.9/21.2 (12.2/9.6)	26.9/21.2 (12.2/9.6)	34.77/28.06 (15.77/12.73)	42.99/34.88 (19.50/15.82)
Liquid /Suction O.D. in	1/4 3/8	1/4 3/8	1/4 3/8	1/4 1/2	1/4 1/2
Moisture Removal Pt./hr	2.3	2.5	3.4	4.2	5.1

Mid-Static Ducted Indoor



Note: MSP ducted units do not include controller. A controller must be ordered separately.

	USYM09UCDSA	USYM12UCDSA	USYM18UCDSA	USYM24UCDSA
UPC	084691851554	084691851561	084691851578	084691851585
Rated Cooling Capacity Btu/hr	9,000	12,000	18,000	24,000
Rated Heating Capacity Btu/hr	10,000	13,000	19,000	25,000
Voltage, Cycle, Phase V/Hz/Phase	208-230/60/1	208-230/60/1	208-230/60/1	208-230/60/1
Airflow (Turbo/High/Med/Low/Quiet) CFM	424/353/294/235/176	494/424/353/294/235	735/635/541/470/400	835/735/635/541/470
Motor Speed RPM (Turbo/High/Med/Low/Quiet)	880/800/720/640/560	950/870/780/680/600	880/820/760/700/640	950/880/820/760/700
Max. External Static Pressure in.W.G (Pa)	0.6 (150)	0.6 (150)	0.6 (150)	0.6 (150)
Indoor Sound Level dB (Turbo/High/Med/Low/Quiet)	44/41/38/35/32	47/44/41/38/35	48/45/42/39/36	50/48/45/42/39
Chassis Dimension: HxWxD in (mm)	9 3/4 x 27 1/2 x 27 1/2 (248 x 700 x 700)	9 3/4 x 27 1/2 x 27 1/2 (248 x 700 x 700)	9 3/4 x 43 3/8 x 27 1/2 (248 x 1100 x 700)	9 3/4 x 43 3/8 x 27 1/2 (248 x 1100 x 700)
Weight Ship/Net - lbs (kg)	66/57 (30/26)	66/57 (30/26)	77/70 (35/32)	77/70 (35/32)
Liquid / Suction O.D. in	1/4 3/8	1/4 3/8	1/4 1/2	3/8 5/8
Drainpipe Size O.D. in	1*	1*	1*	1*
Condensate Pump	Standard	Standard	Standard	Standard
Max. Drain-Lift height in(mm)	27 9/16 (700)	27 9/16 (700)	27 9/16 (700)	27 9/16 (700)

*Condensate drain adapter shipped with the indoor unit is designed to accept a 3/4" PVC pipe.

1. SPECIFICATIONS

Cassette Indoor



	AB09SC2VHA	AB12SC2VHA	AB18SC2VHA
UPC	688057405469	688057405476	688057405483
Rated Cooling Capacity Btu/hr	9,000	12,000	18,000
Rated Heating Capacity Btu/hr	10,000	13,000	19,000
Voltage, Cycle, Phase V/Hz/Phase	208-230/60/1	208-230/60/1	208-230/60/1
Airflow CFM (Turbo/High/Med/Low/Quiet)	410/365/305/265/205	410/365/305/265/205	470/410/365/295/252
Motor Speed RPM (Turbo/High/Med/Low/Quiet)	830/760/690/620/560	830/760/690/620/560	850/800/760/680/590
Indoor Sound dB (Turbo/High/Med/Low/Quiet)	42/40/36/32/25	42/40/36/32/25	45/42/40/36/32
Grille Model	PB-700KB	PB-700KB	PB-700KB
Chassis Dimension: HxWxD in (mm)	10 1/4 x 22 7/16 x 22 7/16 (260 x 570 x 570)	10 1/4 x 22 7/16 x 22 7/16 (260 x 570 x 570)	10 1/4 x 22 7/16 x 22 7/16 (260 x 570 x 570)
Grille Dimension: HxWxD in (mm)	2 3/8 x 27 9/16 x 27 9/16 (60 x 700 x 700)	2 3/8 x 27 9/16 x 27 9/16 (60 x 700 x 700)	2 3/8 x 27 9/16 x 27 9/16 (60 x 700 x 700)
Weight Ship/Net - lbs (kg)	46.3/37.5 (21/17)	46.3/37.5 (21/17)	46.3/37.5 (21/17)
Liquid / Suction O.D. in	1/4 3/8	1/4 3/8	1/4 1/2
Drainpipe Size O.D. in	1 1/4*	1 1/4*	1 1/4*
Condensate Pump	Standard	Standard	Standard
Max. Drain-Lift Height in(mm)	47 1/4 (1200)	47 1/4 (1200)	47 1/4 (1200)

Console Indoor

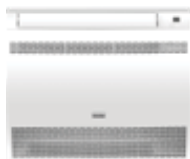

	USYF09UCDWA	USYF12UCDWA	USYF18UCDWA
UPC	084691851523	084691851530	084691851547
Rated Cooling Capacity Btu/hr	9,000	12,000	15,000
Rated Heating Capacity Btu/hr	10,000	13,000	18,000
Voltage, Cycle, Phase V/Hz/Phase	208-230/60/1	208-230/60/1	208-230/60/1
Airflow CFM (Turbo/High/Med/Low/Quiet)	264/235/205/176/147	294/264/235/205/176	341/311/282/252/223
Motor Speed RPM (Turbo/High/Med/Low/Quiet)	650/560/480/410/360	700/590/510/440/390	800/710/630/560/510
Indoor Sound Level dB (Turbo/High/Med/Low/Quiet)	43/40/37/34/31	45/42/39/36/33	49/46/43/40/37
Chassis Dimension: HxWxD in (mm)	23 5/8 x 27 1/2 x 8 3/4 (600 x 700 x 220)	23 5/8 x 27 1/2 x 8 3/4 (600 x 700 x 220)	23 5/8 x 27 1/2 x 8 3/4 (600 x 700 x 220)
Weight Ship/Net - lbs (kg)	35.7/27.8 (16.2/12.6)	35.7/27.8 (16.2/12.6)	45.2/36.6 (20.5/16.6)
Liquid / Suction O.D. in	1/4 3/8	1/4 3/8	1/4 1/2
Drainpipe Size O.D. in	5/8	5/8	5/8

2. SYSTEM

2.1 General

(2.1.1) Description

- A. The multi heat pump air conditioner shall be a variable capacity, mini-split type system comprised of a single outdoor and up to five indoor units.
- B. The multi heat pump air conditioner shall be compatible with any Arctic or FlexFit indoor unit. See combination chart for matching indoor capacity types with an outdoor system.

(2.1.2) Toxicity

- A. The heat pump system shall participate in RoHS compliance and listed in the directory.

2.2 Performance and Operating Range

(2.2.1) Operating Range

- A. With no baffle installed, the heat pump unit shall provide cooling within the ambient temperature of 23°-115°F (-5°~46°C).
- B. With a wind baffle installed, the heat pump unit shall provide cooling within the ambient temperature of 14°-115°F (-10°~46°C).
- C. The heat pump system shall be capable of providing rated heating performance down to -15°F and continuous operation down to -22°F.
- D. The heat pump system shall be capable of 100% rated heating capacity at 5°F (-15°C) outdoor ambient air temperature.

(2.2.2) Performance

- A. Cooling performance rating shall be verified following AHRI 210/240 standards of 80°F DB/67°F WB (27°/19°C) indoor temperature and 95°F DB/75°F WB (35°/24°C) outdoor temperature.
- B. Heating performance rating shall be verified following AHRI 210/240 standards of 70°F DB/60°F WB (21°/16°C) indoor temperature and 47°F DB/43°F WB (8°/6°C) outdoor temperature.

2.3 Combination Tables

2U18MS2HDA

Ducted

Comb.	Combinations			Total Cooling Capacity (Kbtu)	Capacity Indoor Percent (%)			Total Heating Capacity (Kbtu)	Capacity Indoor Percent (%)		
	Unit A	Unit B	Unit C		Unit A	Unit B	Unit C		Unit A	Unit B	Unit C
Two Zone	7	7	—	16.8	50	50	—	17.6	50	50	—
	7	9	—	17.1	43	57	—	18	43	57	—
	7	12	—	17.9	33	67	—	18.4	33	67	—
	9	9	—	18.0	50	50	—	18.5	50	50	—
	9	12	—	18.2	43	57	—	18.8	43	57	—
	12	12	—	18.6	50	50	—	19.2	50	50	—

Non-Ducted

Comb.	Combinations			Total Cooling Capacity (Kbtu)	Capacity Indoor Percent (%)			Total Heating Capacity (Kbtu)	Capacity Indoor Percent (%)		
	Unit A	Unit B	Unit C		Unit A	Unit B	Unit C		Unit A	Unit B	Unit C
Two Zone	7	7	—	16.9	50	50	—	17.8	50	50	—
	7	9	—	17.2	43	57	—	18.2	43	57	—
	7	12	—	17.9	33	67	—	18.4	33	67	—
	9	9	—	18.0	50	50	—	18.5	50	50	—
	9	12	—	18.3	43	57	—	18.9	43	57	—
	12	12	—	18.7	50	50	—	19.4	50	50	—

2. SYSTEM

3U24MS2HDA

Ducted

Comb.	Combinations			Total Cooling Capacity (Kbtu)	Capacity Indoor Percent (%)			Total Heating Capacity (Kbtu)	Capacity Indoor Percent (%)		
	Unit A	Unit B	Unit C		Unit A	Unit B	Unit C		Unit A	Unit B	Unit C
Two Zone	7	7	—	14.1	50	50	—	18.4	50	50	—
	7	9	—	15.3	43	57	—	19.2	43	57	—
	7	12	—	17.4	36	64	—	20	36	64	—
	9	9	—	16.5	50	50	—	20.4	50	50	—
	9	12	—	20.2	43	57	—	21.3	43	57	—
	12	12	—	20.7	50	50	—	21.3	50	50	—
	7	18	—	20.8	28	72	—	21.8	28	72	—
	9	18	—	21	33	67	—	21.9	33	67	—
	12	18	—	21.3	40	60	—	22.3	40	60	—
Three Zone	7	7	7	20.2	33	33	33	21.3	33	33	33
	7	7	9	21.6	30	30	40	22.7	30	30	40
	7	7	12	22.1	26	26	48	23.3	26	26	48
	7	9	9	22.2	28	36	36	23.5	28	36	36
	7	9	12	22.4	25	32	43	24.3	25	32	43
	9	9	9	22.4	33	33	33	25	33	33	33
	9	9	12	22.6	30	30	40	25.5	30	30	40
	7	12	12	22.7	22	39	39	25.7	22	39	39
	7	7	18	22.8	22	22	56	25.8	22	22	56
9	12	12	22.8	28	36	36	25.8	28	36	36	

Non-Ducted

Comb.	Combinations			Total Cooling Capacity (Kbtu)	Capacity Indoor Percent (%)			Total Heating Capacity (Kbtu)	Capacity Indoor Percent (%)		
	Unit A	Unit B	Unit C		Unit A	Unit B	Unit C		Unit A	Unit B	Unit C
Two Zone	7	7	—	14.2	50	50	—	18.5	50	50	—
	7	9	—	15.5	43	57	—	19.3	43	57	—
	7	12	—	17.5	36	64	—	20.1	36	64	—
	9	9	—	16.6	50	50	—	20.5	50	50	—
	9	12	—	20.3	43	57	—	21.3	43	57	—
	12	12	—	20.8	50	50	—	21.4	50	50	—
	7	18	—	21	28	72	—	21.9	28	72	—
	9	18	—	21.2	33	67	—	22	33	67	—
	12	18	—	21.4	40	60	—	22.4	40	60	—
Three Zone	7	7	7	20.2	33	33	33	21.4	33	33	33
	7	7	9	21.7	30	30	40	22.8	30	30	40
	7	7	12	22.1	26	26	48	23.4	26	26	48
	7	9	9	22.3	28	36	36	23.6	28	36	36
	7	9	12	22.4	25	32	43	24.4	25	32	43
	9	9	9	22.4	33	33	33	25	33	33	33
	9	9	12	22.6	30	30	40	25.6	30	30	40
	7	12	12	22.7	22	39	39	25.7	22	39	39
	7	7	18	23	22	22	56	25.9	22	22	56
9	12	12	22.9	28	36	36	25.9	28	36	36	

2. SYSTEM

4U36MS2HDA

Ducted

Comb.	Combinations				Total Cooling Capacity (Kbtu)	Capacity Indoor Percent (%)				Total Heating Capacity (Kbtu)	Capacity Indoor Percent (%)			
	Unit A	Unit B	Unit C	Unit D		Unit A	Unit B	Unit C	Unit D		Unit A	Unit B	Unit C	Unit D
Two Zone	24	7	—	—	33.6	78	22	—	—	35.7	78	22	—	—
	18	9	—	—	31.3	72	28	—	—	33.4	72	28	—	—
	24	9	—	—	32.4	73	27	—	—	34.5	73	27	—	—
	18	12	—	—	32.5	60	40	—	—	34.6	60	40	—	—
	24	12	—	—	33.5	67	33	—	—	35.6	67	33	—	—
	18	18	—	—	33.8	50	50	—	—	35.9	50	50	—	—
	18	24	—	—	34.3	43	57	—	—	36.4	43	57	—	—
	24	24	—	—	34.3	50	50	—	—	36.4	50	50	—	—
Three Zone	18	7	7	—	34.4	56	22	22	—	36.5	56	22	22	—
	24	7	9	—	34.6	60	18	12	—	36.7	60	18	12	—
	7	7	12	—	30.2	27	27	46	—	32.3	27	27	46	—
	12	9	7	—	31	43	32	25	—	33.1	43	32	25	—
	18	9	7	—	34.5	53	26	21	—	36.6	53	26	21	—
	24	7	7	—	34.6	60	22	18	—	36.7	60	22	18	—
	12	12	7	—	34	39	39	22	—	36.1	39	39	22	—
	18	12	7	—	34	48	32	20	—	36.1	48	32	20	—
	24	12	7	—	34.8	56	28	16	—	36.9	56	28	16	—
	9	9	9	—	30.5	33	33	33	—	32.6	33	33	33	—
	12	9	9	—	31.2	40	30	30	—	33.3	40	30	30	—
	18	9	9	—	34.5	50	25	25	—	36.6	50	25	25	—
	24	9	9	—	34.8	76	12	12	—	36.9	76	12	12	—
	12	12	9	—	34	36	36	28	—	36.1	36	36	28	—
	18	12	9	—	34.2	46	33	21	—	36.3	46	33	21	—
	24	12	9	—	34.9	53	26	21	—	37	53	26	21	—
	12	12	12	—	33.9	33	33	33	—	36	33	33	33	—
18	12	12	—	34.6	42	29	29	—	36.7	42	29	29	—	
24	12	12	—	35.1	50	25	25	—	37.2	50	25	25	—	
18	18	9	—	34.9	40	40	20	—	37	40	40	20	—	
18	18	12	—	35.1	37	37	26	—	37.2	37	37	26	—	
Four Zone	7	7	7	7	30.9	25	25	25	25	33	25	25	25	25
	9	7	7	7	32.2	30	23	23	23	34.3	30	23	23	23
	12	7	7	7	33.9	36	21	21	21	36	36	21	21	21
	18	7	7	7	34.7	46	18	18	18	36.8	46	18	18	18
	24	7	7	7	35.5	53	15	15	15	37.6	53	15	15	15
	9	9	7	7	34	28	28	27	27	36.1	28	28	27	27
	12	9	7	7	34.3	34	25	20	20	36.4	34	25	20	20
	18	9	7	7	35	43	21	18	18	37.1	43	21	18	18
	24	9	7	7	35.8	51	21	14	14	37.9	51	21	14	14
	12	12	7	7	34	31	31	19	19	36.1	31	31	19	19
	18	12	7	7	35.7	40	28	16	16	37.8	40	28	16	16
	9	9	9	7	34.1	27	27	27	19	36.2	27	27	27	19
	12	9	9	7	34.4	32	25	25	18	36.5	32	25	25	18
	18	9	9	7	35.2	42	21	21	16	37.3	42	21	21	16
	12	12	9	7	34.3	30	30	22	18	36.4	30	30	22	18
	12	12	12	7	34.4	28	28	28	16	36.5	28	28	28	16
	9	9	9	9	34	25	25	25	25	36	25	25	25	25
	12	9	9	9	34.5	30	23	23	23	36.6	30	23	23	23
	12	12	9	9	35.2	37	37	13	13	37.3	37	37	13	13
18	12	9	9	35.8	37	25	19	19	37.9	37	25	19	19	
12	12	12	9	35.5	26	26	26	22	37.6	26	26	26	22	
12	12	12	12	35.9	25	25	25	25	38	25	25	25	25	

2. SYSTEM

4U36MS2HDA

Non-Ducted

Comb.	Combinations				Total Cooling Capacity (Kbtu)	Capacity Indoor Percent (%)				Total Heating Capacity (Kbtu)	Capacity Indoor Percent (%)			
	Unit A	Unit B	Unit C	Unit D		Unit A	Unit B	Unit C	Unit D		Unit A	Unit B	Unit C	Unit D
Two Zone	24	7	—	—	33.7	78	22	—	—	35.8	78	22	—	—
	18	9	—	—	31.5	72	28	—	—	33.6	72	28	—	—
	24	9	—	—	32.5	73	27	—	—	34.6	73	27	—	—
	18	12	—	—	32.6	60	40	—	—	34.7	60	40	—	—
	24	12	—	—	33.8	67	33	—	—	35.7	67	33	—	—
	18	18	—	—	33.9	50	50	—	—	36	50	50	—	—
	18	24	—	—	34.4	43	57	—	—	36.5	43	57	—	—
	24	24	—	—	34.5	50	50	—	—	36.6	50	50	—	—
Three Zone	18	7	7	—	34.5	56	22	22	—	36.6	56	22	22	—
	24	7	9	—	34.7	60	18	12	—	36.8	60	18	12	—
	7	7	12	—	30.3	27	27	46	—	32.4	27	27	46	—
	12	9	7	—	31.1	43	32	25	—	33.2	43	32	25	—
	18	9	7	—	34.6	53	26	21	—	36.7	53	26	21	—
	24	7	7	—	34.7	60	22	18	—	36.8	60	22	18	—
	12	12	7	—	34.1	39	39	22	—	36.2	39	39	22	—
	18	12	7	—	34.1	48	32	20	—	36.2	48	32	20	—
	24	12	7	—	34.9	56	28	16	—	37	56	28	16	—
	9	9	9	—	30.6	33	33	33	—	32.7	33	33	33	—
	12	9	9	—	31.3	40	30	30	—	33.4	40	30	30	—
	18	9	9	—	34.6	50	25	25	—	36.7	50	25	25	—
	24	9	9	—	34.9	76	12	12	—	37	76	12	12	—
	12	12	9	—	34.1	36	36	28	—	36.2	36	36	28	—
	18	12	9	—	34.3	46	33	21	—	36.4	46	33	21	—
	24	12	9	—	35	53	26	21	—	37.1	53	26	21	—
	12	12	12	—	34	33	33	33	—	36.1	33	33	33	—
	18	12	12	—	34.7	42	29	29	—	36.8	42	29	29	—
24	12	12	—	35.2	50	25	25	—	37.3	50	25	25	—	
18	18	9	—	35					37.1					
18	18	12	—	35.2	37	37	26	—	37.3	37	37	26	—	
Four Zone	7	7	7	7	31	25	25	25	25	33.1	25	25	25	25
	9	7	7	7	32.3	30	23	23	23	34.4	30	23	23	23
	12	7	7	7	34	36	21	21	21	36.1	36	21	21	21
	18	7	7	7	34.8	46	18	18	18	36.9	46	18	18	18
	24	7	7	7	35.6	53	15	15	15	37.7	53	15	15	15
	9	9	7	7	34.1	28	28	27	27	36.2	28	28	27	27
	12	9	7	7	34.4	34	25	20	20	36.5	34	25	20	20
	18	9	7	7	35.1	43	21	18	18	37.2	43	21	18	18
	24	9	7	7	35.9	51	21	14	14	38	51	21	14	14
	12	12	7	7	34.1	31	31	19	19	36.2	31	31	19	19
	18	12	7	7	35.8	40	28	16	16	37.9	40	28	16	16
	9	9	9	7	34.2	27	27	27	19	36.3	27	27	27	19
	12	9	9	7	34.5	32	25	25	18	36.6	32	25	25	18
	18	9	9	7	35.3	42	21	21	16	37.4	42	21	21	16
	12	12	9	7	34.4	30	30	22	18	36.5	30	30	22	18
	12	12	12	7	34.5	28	28	28	16	36.6	28	28	28	16
	9	9	9	9	34	25	25	25	25	36	25	25	25	25
	12	9	9	9	34.6	30	23	23	23	36.7	30	23	23	23
12	12	9	9	35.3	37	37	13	13	37.4	37	37	13	13	
18	12	9	9	35.9	37	25	19	19	38	37	25	19	19	
12	12	12	9	35.6	26	26	26	22	37.7	26	26	26	22	
12	12	12	12	36	25	25	25	25	38.1	25	25	25	25	

2. SYSTEM

ENGLISH

5U45MS2HDA

Ducted

Comb.	Combinations					Total Cooling Capacity (Kbtu)	Capacity Indoor Percent (%)					Total Heating Capacity (Kbtu)	Capacity Indoor Percent (%)				
	Unit A	Unit B	Unit C	Unit D	Unit E		Unit A	Unit B	Unit C	Unit D	Unit E		Unit A	Unit B	Unit C	Unit D	Unit E
Two Zone	24	7	—	—	—	37.2	77	23	—	—	—	38.8	77	23	—	—	—
	18	9	—	—	—	37.0	67	33	—	—	—	38.4	67	33	—	—	—
	24	9	—	—	—	37.7	73	27	—	—	—	39.1	73	27	—	—	—
	18	12	—	—	—	37.4	60	40	—	—	—	38.6	60	40	—	—	—
	24	12	—	—	—	38.0	67	33	—	—	—	39.5	67	33	—	—	—
	18	18	—	—	—	38.3	50	50	—	—	—	39.8	50	50	—	—	—
	18	24	—	—	—	38.8	43	57	—	—	—	40.3	43	57	—	—	—
	24	24	—	—	—	39.7	50	50	—	—	—	41.2	50	50	—	—	—
Three Zone	18	7	7	—	—	37.8	56	22	22	—	—	39.5	56	22	22	—	—
	7	9	12	—	—	37.4	25	32	43	—	—	38.7	25	32	43	—	—
	7	9	18	—	—	38.1	21	26	53	—	—	39.7	21	26	53	—	—
	7	12	12	—	—	37.7	22	39	39	—	—	39.3	22	39	39	—	—
	7	18	18	—	—	39.5	16	42	42	—	—	40.8	16	42	42	—	—
	9	9	9	—	—	37.3	33	33	33	—	—	38.6	33	33	33	—	—
	9	9	12	—	—	37.6	30	30	40	—	—	39.1	30	30	40	—	—
	9	12	12	—	—	38.0	27	36	36	—	—	39.5	27	36	36	—	—
	18	18	18	—	—	40.6	33	33	33	—	—	42.1	33	33	33	—	—
	24	7	9	—	—	39.1	60	18	12	—	—	40.6	60	18	12	—	—
	24	7	7	—	—	38.9	60	22	18	—	—	40.4	60	22	18	—	—
	18	12	7	—	—	38.5	48	32	20	—	—	40.0	48	32	20	—	—
	24	12	7	—	—	39.4	56	28	16	—	—	40.9	56	28	16	—	—
	18	9	9	—	—	38.6	50	25	25	—	—	40.1	50	25	25	—	—
	24	9	9	—	—	39.3	76	12	12	—	—	40.8	76	12	12	—	—
	18	12	9	—	—	38.7	46	33	21	—	—	40.2	46	33	21	—	—
	24	12	9	—	—	39.5	53	26	21	—	—	41.0	53	26	21	—	—
	12	12	12	—	—	38.4	33	33	33	—	—	39.9	33	33	33	—	—
	18	12	12	—	—	39.1	42	29	29	—	—	40.6	42	29	29	—	—
	24	12	12	—	—	39.7	50	25	25	—	—	41.2	50	25	25	—	—
	18	18	9	—	—	39.4	40	40	20	—	—	40.9	40	40	20	—	—
	18	18	12	—	—	39.8	37	37	26	—	—	41.3	37	37	26	—	—
	24	18	7	—	—	39.8	49	37	14	—	—	41.3	49	37	14	—	—
	24	18	9	—	—	40.1	47	35	18	—	—	41.6	47	35	18	—	—
24	18	12	—	—	40.5	45	33	22	—	—	42.0	45	33	22	—	—	
Four Zone	7	7	7	7	—	37.0	25	25	25	—	—	38.6	25	25	25	—	—
	7	7	7	9	—	37.2	23	23	30	—	—	38.8	23	23	30	—	—
	7	7	7	12	—	37.7	21	21	36	—	—	39.2	21	21	36	—	—
	7	7	9	9	—	37.5	22	28	28	—	—	39.0	22	28	28	—	—
	7	7	9	12	—	38.0	20	26	34	—	—	39.5	20	26	34	—	—
	7	7	18	18	—	40.6	14	36	36	—	—	42.2	14	36	36	—	—
	7	7	18	24	—	41.3	13	32	43	—	—	42.8	13	32	43	—	—
	7	9	9	9	—	37.9	26	26	26	—	—	39.3	26	26	26	—	—
	7	9	12	18	—	39.9	20	26	39	—	—	41.1	20	26	39	—	—
	7	9	12	24	—	40.8	17	23	46	—	—	42.2	17	23	46	—	—
	7	9	18	18	—	40.8	17	35	35	—	—	42.3	17	35	35	—	—
	7	12	18	18	—	41.1	22	33	33	—	—	42.7	22	33	33	—	—
	9	9	12	24	—	40.9	17	22	44	—	—	42.5	17	22	44	—	—
	9	9	18	18	—	41.0	17	33	33	—	—	42.6	17	33	33	—	—
	18	7	7	7	—	38.5	46	18	18	18	—	40.0	46	18	18	18	—
	24	7	7	7	—	39.4	53	15	15	15	—	40.9	53	15	15	15	—
	18	9	7	7	—	39.2	43	21	18	18	—	40.7	43	21	18	18	—
	24	9	7	7	—	40.0	51	21	14	14	—	41.5	51	21	14	14	—
	12	12	7	7	—	38.4	31	31	19	19	—	39.9	31	31	19	19	—
	18	12	7	7	—	39.5	40	28	16	16	—	41.0	40	28	16	16	—
	12	9	9	7	—	38.4	32	25	25	18	—	39.9	32	25	25	18	—
	18	9	9	7	—	39.4	42	21	21	16	—	40.9	42	21	21	16	—
	12	12	9	7	—	38.7	30	30	22	18	—	40.2	30	30	22	18	—
	12	12	12	7	—	39.3	28	28	28	16	—	40.8	28	28	28	16	—
	9	9	9	9	—	38.2	25	25	25	25	—	39.7	25	25	25	25	—
	12	9	9	9	—	38.7	30	23	23	23	—	40.2	30	23	23	23	—
	12	12	9	9	—	39.4	37	37	13	13	—	40.9	37	37	13	13	—
	18	12	9	9	—	40.0	37	25	19	19	—	41.5	37	25	19	19	—
	12	12	12	9	—	39.6	26	26	26	22	—	41.1	26	26	26	22	—
	12	12	12	12	—	40.3	25	25	25	25	—	41.8	25	25	25	25	—
	18	12	12	7	—	40.5	36	25	25	14	—	42.0	36	25	25	14	—
	18	12	12	9	—	40.8	35	24	33	18	—	42.3	35	24	33	18	—
18	12	12	12	—	41.2	33	22	33	22	—	42.7	33	22	33	22	—	

2. SYSTEM

Ducted

Comb.	Combinations					Total Cooling Capacity (Kbtu)	Capacity Indoor Percent (%)					Total Heating Capacity (Kbtu)	Capacity Indoor Percent (%)				
	Unit A	Unit B	Unit C	Unit D	Unit E		Unit A	Unit B	Unit C	Unit D	Unit E		Unit A	Unit B	Unit C	Unit D	Unit E
Five Zone	7	7	7	7	7	38.3	20	20	20	20	20	40.3	20	20	20	20	20
	7	7	7	7	24	41.0	13	13	13	13	46	42.3	13	13	13	13	46
	7	7	7	9	24	41.3	13	13	13	17	44	42.5	13	13	13	17	44
	7	7	9	9	24	41.6	13	13	16	16	42	42.9	13	13	16	16	42
	7	9	9	9	24	41.7	12	16	16	16	41	43.2	12	16	16	16	41
	9	9	9	9	24	41.7	15	15	15	15	40	43.2	15	15	15	15	40
	7	7	7	12	24	41.6	12	12	12	21	42	43.1	12	12	12	21	42
	7	7	9	12	24	41.7	12	12	15	20	41	43.2	12	12	15	20	41
	7	7	12	12	18	41.6	13	13	21	21	32	42.9	13	13	21	21	32
	7	9	12	12	18	41.7	12	16	21	21	31	43.2	12	16	21	21	31
	7	12	12	12	12	41.4	13	22	22	22	22	42.7	13	22	22	22	22
	9	9	9	9	18	41.3	17	17	17	17	33	42.5	17	17	17	17	33
	9	9	9	12	18	41.6	16	16	16	21	32	43.0	16	16	16	21	32
	9	9	12	12	18	41.7	15	15	20	20	30	43.2	15	15	20	20	30
	9	12	12	12	12	41.6	16	21	21	21	21	43.0	16	21	21	21	21
	12	12	12	12	12	41.7	20	20	20	20	20	43.2	20	20	20	20	20
	7	9	12	12	18	41.6	12	16	21	21	31	43.2	12	16	21	21	31
	12	12	12	12	7	41.4	22	22	22	22	13	42.7	22	22	22	22	13
	9	9	9	9	9	40.0	20	20	20	20	20	41.5	20	20	20	20	20
	9	9	9	9	7	39.7	21	21	21	21	16	41.2	21	21	21	21	16
	9	9	9	7	7	39.3	22	22	22	17	17	40.8	22	22	22	17	17
	9	9	7	7	7	38.9	23	23	18	18	18	40.4	23	23	18	18	18
	9	7	7	7	7	38.6	24	19	19	19	19	40.1	24	19	19	19	19
	12	9	9	9	9	40.5	25	19	19	19	19	42.0	25	19	19	19	19
	12	12	9	9	9	40.9	24	24	18	18	18	42.4	24	24	18	18	18
	12	12	12	9	9	41.5	22	22	22	17	17	43.0	22	22	22	17	17
	12	7	7	7	7	39.2	30	18	18	18	18	40.7	30	18	18	18	18
	12	12	7	7	7	39.8	27	27	16	16	16	41.3	27	27	16	16	16
	12	12	12	7	7	40.7	24	24	24	14	14	42.2	24	24	24	14	14
	12	9	7	7	7	39.1	29	21	17	17	17	40.6	29	21	17	17	17
	12	9	9	7	7	39.8	27	20	20	16	16	41.3	27	20	20	16	16
	12	9	9	9	7	40.1	26	20	20	20	15	41.6	26	20	20	20	15
	12	12	9	7	7	40.2	26	26	19	15	15	41.7	26	26	19	15	15
	12	12	9	9	7	40.6	24	24	18	18	15	42.1	24	24	18	18	15
	12	12	12	9	7	41.0	23	23	23	17	13	42.5	23	23	23	17	13
	18	7	7	7	7	40.0	39	15	15	15	15	41.5	39	15	15	15	15
	18	9	7	7	7	40.4	38	19	15	15	15	41.9	38	19	15	15	15
	18	9	9	7	7	40.7	36	18	18	14	14	42.2	36	18	18	14	14
	18	9	9	9	7	40.9	35	17	17	17	13	42.4	35	17	17	17	13
	18	12	7	7	7	40.8	35	24	14	14	14	42.3	35	24	14	14	14
18	12	9	7	7	41.0	33	20	20	13	13	42.5	33	20	20	13	13	
18	12	9	9	7	41.3	33	22	16	16	13	42.8	33	22	16	16	13	

2. SYSTEM

5U45MS2HDA

Non-Ducted

Comb.	Combinations					Total Cooling Capacity (Kbtu)	Capacity Indoor Percent (%)					Total Heating Capacity (Kbtu)	Capacity Indoor Percent (%)				
	Unit A	Unit B	Unit C	Unit D	Unit E		Unit A	Unit B	Unit C	Unit D	Unit E		Unit A	Unit B	Unit C	Unit D	Unit E
Two Zone	24	7	—	—	—	38.3	77	23	—	—	—	39.3	77	23	—	—	—
	18	9	—	—	—	38.0	67	33	—	—	—	38.9	67	33	—	—	—
	24	9	—	—	—	38.8	73	27	—	—	—	39.6	73	27	—	—	—
	18	12	—	—	—	38.4	60	40	—	—	—	39.1	60	40	—	—	—
	24	12	—	—	—	39.0	67	33	—	—	—	40.0	67	33	—	—	—
	18	18	—	—	—	39.4	50	50	—	—	—	40.3	50	50	—	—	—
	18	24	—	—	—	39.8	43	57	—	—	—	40.8	43	57	—	—	—
	24	24	—	—	—	40.7	50	50	—	—	—	41.7	50	50	—	—	—
Three Zone	18	7	7	—	—	38.8	56	22	22	—	—	40.0	56	22	22	—	—
	7	9	12	—	—	38.4	25	32	43	—	—	39.2	25	32	43	—	—
	7	9	18	—	—	39.1	21	26	53	—	—	40.2	21	26	53	—	—
	7	12	12	—	—	38.7	22	39	39	—	—	39.8	22	39	39	—	—
	7	18	18	—	—	40.5	16	42	42	—	—	41.3	16	42	42	—	—
	9	9	9	—	—	38.3	33	33	33	—	—	39.1	33	33	33	—	—
	9	9	12	—	—	38.6	30	30	40	—	—	39.6	30	30	40	—	—
	9	12	12	—	—	39.0	27	36	36	—	—	40.0	27	36	36	—	—
	18	18	18	—	—	41.6	33	33	33	—	—	42.6	33	33	33	—	—
	24	7	9	—	—	40.1	60	18	12	—	—	41.1	60	18	12	—	—
	24	7	7	—	—	39.9	60	22	18	—	—	40.9	60	22	18	—	—
	18	12	7	—	—	39.5	48	32	20	—	—	40.5	48	32	20	—	—
	24	12	7	—	—	40.4	56	28	16	—	—	41.4	56	28	16	—	—
	18	9	9	—	—	39.6	50	25	25	—	—	40.6	50	25	25	—	—
	24	9	9	—	—	40.3	76	12	12	—	—	41.3	76	12	12	—	—
	18	12	9	—	—	39.7	46	33	21	—	—	40.7	46	33	21	—	—
	24	12	9	—	—	40.5	53	26	21	—	—	41.5	53	26	21	—	—
	12	12	12	—	—	39.4	33	33	33	—	—	40.4	33	33	33	—	—
	18	12	12	—	—	40.1	42	29	29	—	—	41.1	42	29	29	—	—
	24	12	12	—	—	40.7	50	25	25	—	—	41.7	50	25	25	—	—
	18	18	9	—	—	40.4	40	40	20	—	—	41.4	40	40	20	—	—
	18	18	12	—	—	40.8	37	37	26	—	—	41.8	37	37	26	—	—
	24	18	7	—	—	40.8	49	37	14	—	—	41.8	49	37	14	—	—
	24	18	9	—	—	41.1	47	35	18	—	—	42.1	47	35	18	—	—
24	18	12	—	—	41.5	45	33	22	—	—	42.5	45	33	22	—	—	
Four Zone	7	7	7	7	—	38.0	25	25	25	—	—	39.1	25	25	25	—	—
	7	7	7	9	—	38.2	23	23	30	—	—	39.3	23	23	30	—	—
	7	7	7	12	—	38.7	21	21	36	—	—	39.7	21	21	36	—	—
	7	7	9	9	—	38.5	22	28	28	—	—	39.5	22	28	28	—	—
	7	7	9	12	—	39.0	20	26	34	—	—	40.0	20	26	34	—	—
	7	7	18	18	—	41.6	14	36	36	—	—	42.7	14	36	36	—	—
	7	7	18	24	—	42.3	13	32	43	—	—	43.3	13	32	43	—	—
	7	9	9	9	—	38.9	26	26	26	—	—	39.8	26	26	26	—	—
	7	9	12	18	—	40.9	20	26	39	—	—	41.6	20	26	39	—	—
	7	9	12	24	—	41.8	17	23	46	—	—	42.7	17	23	46	—	—
	7	9	18	18	—	41.8	17	35	35	—	—	42.8	17	35	35	—	—
	7	12	18	18	—	42.1	22	33	33	—	—	43.2	22	33	33	—	—
	9	9	12	24	—	41.9	17	22	44	—	—	43.0	17	22	44	—	—
	9	9	18	18	—	42.0	17	33	33	—	—	43.1	17	33	33	—	—
	18	7	7	7	—	39.5	46	18	18	18	—	40.5	46	18	18	18	—
	24	7	7	7	—	40.4	53	15	15	15	—	41.4	53	15	15	15	—
	18	9	7	7	—	40.2	43	21	18	18	—	41.2	43	21	18	18	—
	24	9	7	7	—	41.0	51	21	14	14	—	42.0	51	21	14	14	—
	12	12	7	7	—	39.4	31	31	19	19	—	40.4	31	31	19	19	—
	18	12	7	7	—	40.5	40	28	16	16	—	41.5	40	28	16	16	—
	12	9	9	7	—	39.4	32	25	25	18	—	40.4	32	25	25	18	—
	18	9	9	7	—	40.4	42	21	21	16	—	41.4	42	21	21	16	—
	12	12	9	7	—	39.7	30	30	22	18	—	40.7	30	30	22	18	—
	12	12	12	7	—	40.3	28	28	28	16	—	41.3	28	28	28	16	—
	9	9	9	9	—	39.2	25	25	25	25	—	40.2	25	25	25	25	—
	12	9	9	9	—	39.7	30	23	23	23	—	40.7	30	23	23	23	—
	12	12	9	9	—	40.4	37	37	13	13	—	41.4	37	37	13	13	—
	18	12	9	9	—	41.0	37	25	19	19	—	42.0	37	25	19	19	—
	12	12	12	9	—	40.6	26	26	26	22	—	41.6	26	26	26	22	—
	12	12	12	12	—	41.3	25	25	25	25	—	42.3	25	25	25	25	—
	18	12	12	7	—	41.5	36	25	25	14	—	42.5	36	25	25	14	—
	18	12	12	9	—	41.8	35	24	33	18	—	42.8	35	24	33	18	—
18	12	12	12	—	42.2	33	22	33	22	—	43.2	33	22	33	22	—	

2. SYSTEM

5U45MS2HDA

Non-Ducted

Comb.	Combinations					Total Cooling Capacity (Kbtu)	Capacity Indoor Percent (%)					Total Heating Capacity (Kbtu)	Capacity Indoor Percent (%)				
	Unit A	Unit B	Unit C	Unit D	Unit E		Unit A	Unit B	Unit C	Unit D	Unit E		Unit A	Unit B	Unit C	Unit D	Unit E
Five Zone	7	7	7	7	7	39.3	20	20	20	20	20	40.8	20	20	20	20	20
	7	7	7	7	24	42.0	13	13	13	13	46	42.8	13	13	13	13	46
	7	7	7	9	24	42.3	13	13	13	17	44	43.0	13	13	13	17	44
	7	7	9	9	24	42.6	13	13	16	16	42	43.4	13	13	16	16	42
	7	9	9	9	24	42.7	12	16	16	16	41	43.7	12	16	16	16	41
	9	9	9	9	24	42.7	15	15	15	15	40	43.7	15	15	15	15	40
	7	7	7	12	24	42.6	12	12	12	21	42	43.6	12	12	12	21	42
	7	7	9	12	24	42.7	12	12	15	20	41	43.7	12	12	15	20	41
	7	7	12	12	18	42.6	13	13	21	21	32	43.4	13	13	21	21	32
	7	9	12	12	18	42.7	12	16	21	21	31	43.7	12	16	21	21	31
	7	12	12	12	12	42.4	13	22	22	22	22	43.2	13	22	22	22	22
	9	9	9	9	18	42.3	17	17	17	17	33	43.0	17	17	17	17	33
	9	9	9	12	18	42.6	16	16	16	21	32	43.5	16	16	16	21	32
	9	9	12	12	18	42.7	15	15	20	20	30	43.7	15	15	20	20	30
	9	12	12	12	12	42.6	16	21	21	21	21	43.5	16	21	21	21	21
	12	12	12	12	12	42.7	20	20	20	20	20	43.7	20	20	20	20	20
	7	9	12	12	18	42.6	12	16	21	21	31	43.7	12	16	21	21	31
	12	12	12	12	7	42.4	22	22	22	22	13	43.2	22	22	22	22	13
	9	9	9	9	9	41.0	20	20	20	20	20	42.0	20	20	20	20	20
	9	9	9	9	7	40.7	21	21	21	21	16	41.7	21	21	21	21	16
	9	9	9	7	7	40.3	22	22	22	17	17	41.3	22	22	22	17	17
	9	9	7	7	7	39.9	23	23	18	18	18	40.9	23	23	18	18	18
	9	7	7	7	7	39.6	24	19	19	19	19	40.6	24	19	19	19	19
	12	9	9	9	9	41.5	25	19	19	19	19	42.5	25	19	19	19	19
	12	12	9	9	9	41.9	24	24	18	18	18	42.9	24	24	18	18	18
	12	12	12	9	9	42.5	22	22	22	17	17	43.5	22	22	22	17	17
	12	7	7	7	7	40.2	30	18	18	18	18	41.2	30	18	18	18	18
	12	12	7	7	7	40.8	27	27	16	16	16	41.8	27	27	16	16	16
	12	12	12	7	7	41.7	24	24	24	14	14	42.7	24	24	24	14	14
	12	9	7	7	7	40.1	29	21	17	17	17	41.1	29	21	17	17	17
	12	9	9	7	7	40.8	27	20	20	16	16	41.8	27	20	20	16	16
	12	9	9	9	7	41.1	26	20	20	20	15	42.1	26	20	20	20	15
	12	12	9	7	7	41.2	26	26	19	15	15	42.2	26	26	19	15	15
	12	12	9	9	7	41.6	24	24	18	18	15	42.6	24	24	18	18	15
	12	12	12	9	7	42.0	23	23	23	17	13	43.0	23	23	23	17	13
	18	7	7	7	7	41.0	39	15	15	15	15	42.0	39	15	15	15	15
	18	9	7	7	7	41.4	38	19	15	15	15	42.4	38	19	15	15	15
	18	9	9	7	7	41.7	36	18	18	14	14	42.7	36	18	18	14	14
	18	9	9	9	7	41.9	35	17	17	17	13	42.9	35	17	17	17	13
	18	12	7	7	7	41.8	35	24	14	14	14	42.8	35	24	14	14	14
18	12	9	7	7	42.0	33	20	20	13	13	43.0	33	20	20	13	13	
18	12	9	9	7	42.3	33	22	16	16	13	43.3	33	22	16	16	13	

2.4 Installation Requirements

(2.4.1) Lineset

- A. The connecting refrigerant lines between the indoor and outdoor units are to be supplied by the installer.
- B. The tubing must be annealed ACR-type copper, meeting ASTM B280 standards.
- C. The connecting tubing between the outdoor and indoor units shall be continuous in all possible situations.
- D. The tubing ends must be reamed inside and out, and must be flared using a 45° flaring tool approved for R-410A.
- E. Connections to the indoor and outdoor units shall be made with flare nuts that are supplied with the individual units.
- F. The flare nuts must be attached to indoor and outdoor units using a torque wrench and back- up wrench.

Pipe Size	Torque	A (inch)	Flare Shape
1/4	12 lb/ft 16.3 Nm	0.327-0.343	
3/8	27 lb/ft 36.6 Nm	0.472-0.488	
1/2	40 lb/ft 54.2 Nm	0.488-0.654	
5/8	50 lb/ft 67.8 Nm	0.732-0.748	
3/4	80 lb/ft 108.5 Nm	0.902-0.917	

- G. Each tube must be insulated with a minimum of 1/2 inch (12.7mm) closed-foam insulation that is UV resistant and meets ASTM Standard E84 25/50 flame spread/smoke development.
- H. The lineset between the indoor and outdoor must not exceed the listed maximum length and maximum height difference (See section **1. Specifications**, outdoor units).



2.5 Electrical Requirements

(2.5.1) Electrical Supply

- A. The operating electrical requirements shall be 208/230 volts AC, single-phase, 60 hertz. Voltage supplied to the outdoor unit must be between 187-253 volts.
- B. Power supply must be installed in accordance to NEC standards.

(2.5.2) Connecting Wire to Indoor

- A. Connecting cable between the indoor unit(s) must be made with 4 conductor - 14 AWG stranded copper wire.
- B. Connecting wire must be continuous (without break) unless local code requires power disconnect next to indoor unit. If a disconnect is required by local code, it must be a 3-pole, single-throw type.

3. OUTDOOR UNITS

3.1 Dimensions

2U18MS2HDA, 3U24MS2HDA

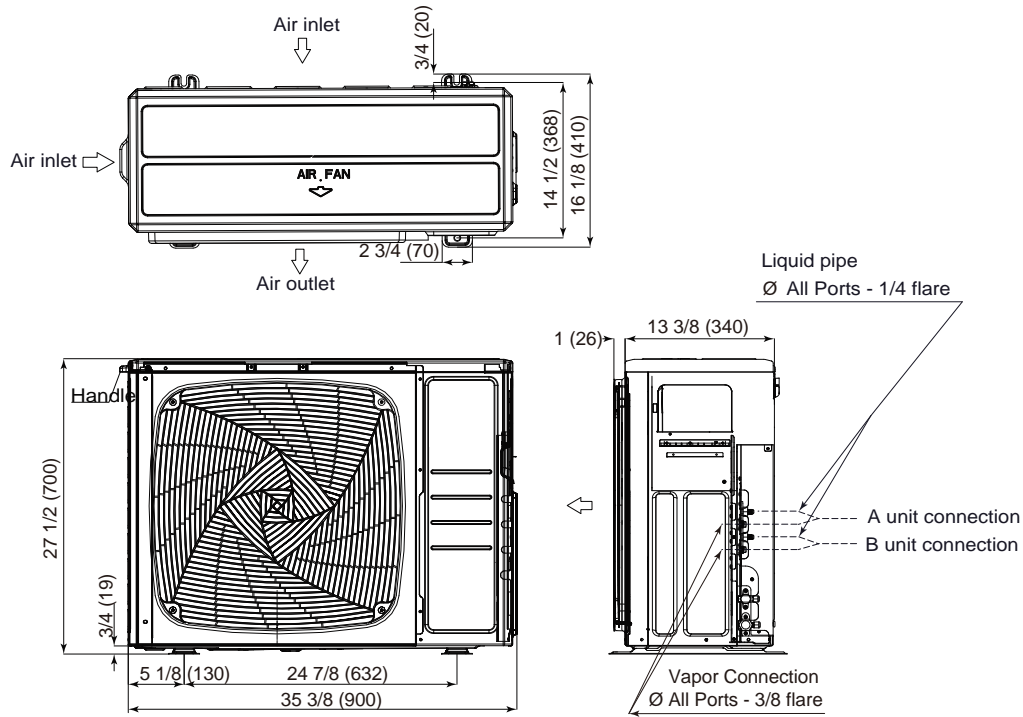

4U36MS2HDA

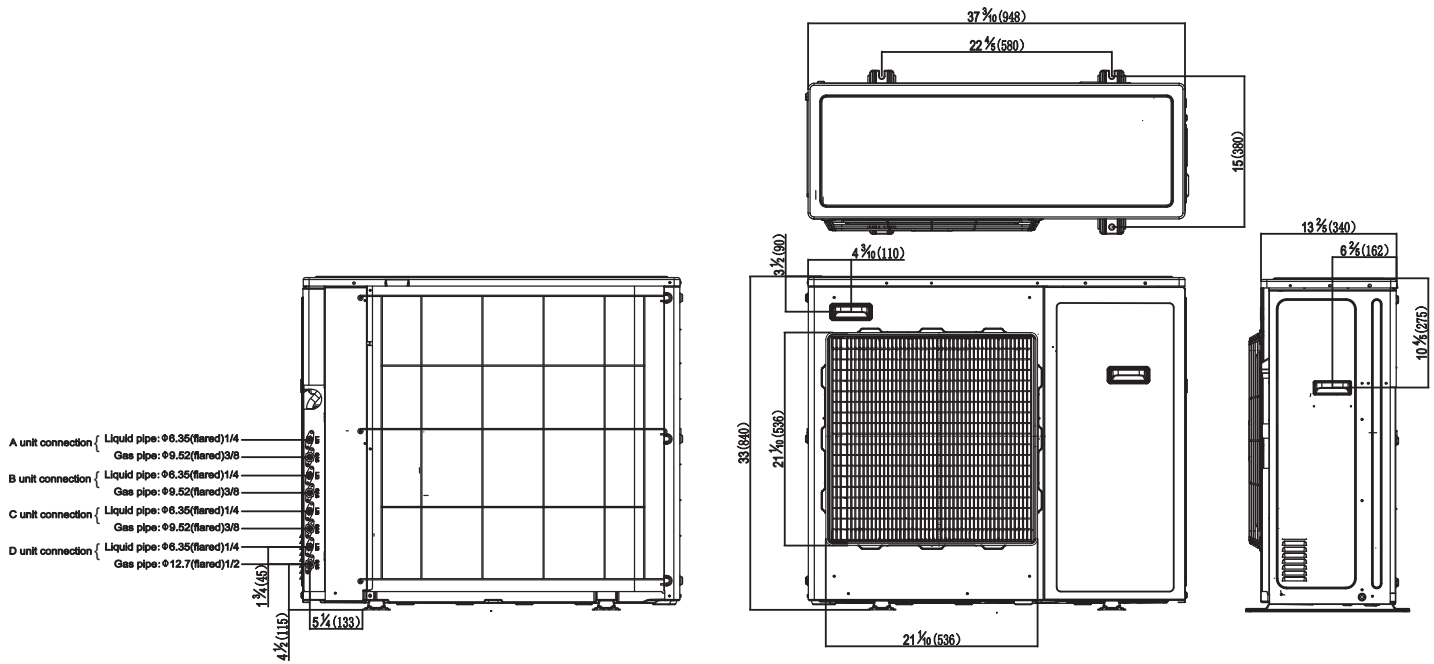

3. OUTDOOR UNITS

5U42MS2HDA

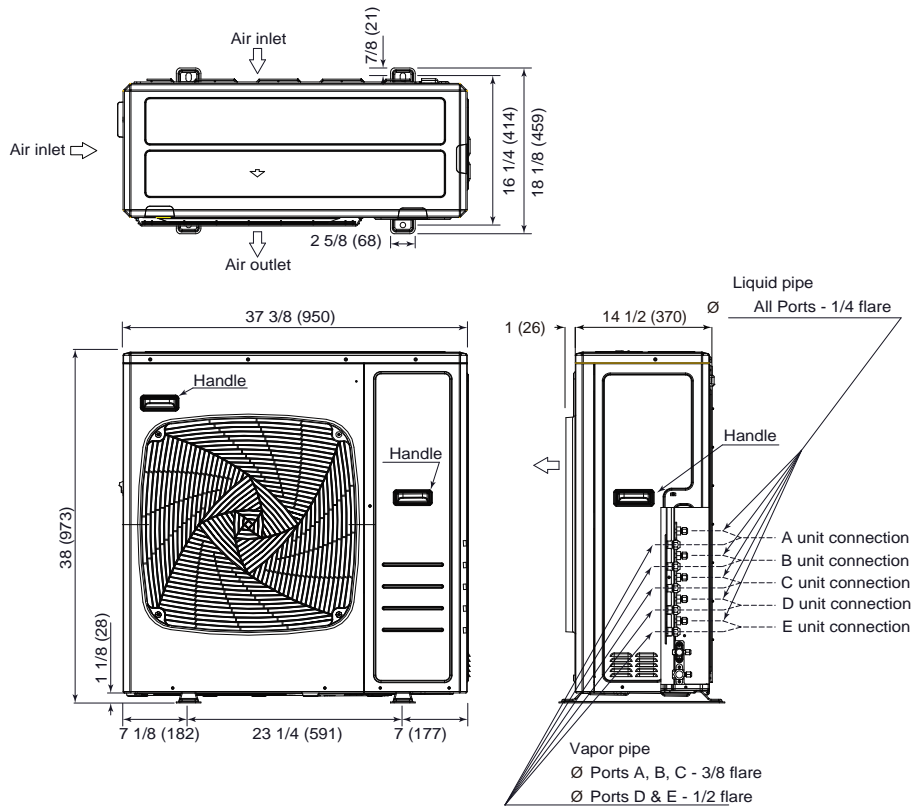

3.2 General

(3.2.1) Outdoor Unit Description

- A. The outdoor unit shall be comprised of a condenser coil with all components and controls necessary to perform the rated operation.

(3.2.2) Sound Pressure Rating

- A. Sound pressure rating as measured according to test standard JIS C 961:

Model	Sound Pressure Rating dB(A)
2U18MS2HDA	51
3U24MS2HDA	53
4U36MS2HDA	58
5U42MS2HDA	63

(3.2.3) Warranty

- A. The outdoor unit shall be covered by a manufacturer's parts warranty (See Section 10. Limited Warranty)

3.3 Installation

(3.3.1) Condensate

- A. The installer must adhere to local building codes for managing condensate water produced by the outdoor unit.

(3.3.2) Clearances

- A. The installer must follow the recommended clearances provided in the Installation Manual.

3.4 Components

(3.4.1) Coil

- A. The outdoor coil shall be made with a blue colored hydrophilic coating on the aluminum fins and packed with internally grooved copper tubing, to increase the effective heat exchange surface area by 25%, resulting in higher efficiencies and shorter defrost cycles (approx. 29%.)
- B. Coils shall be helium pressure tested at the factory within a range of 600 - 650 PSI.
- C. Outdoor unit shall be factory charged with R-410A refrigerant for 100 feet of lineset.

(3.4.2) Fan Motor

- A. The outdoor fan motor shall be a brushless, variable speed DCV motor type.
- B. The fan motor shall be molded with heat-hardened resin.
- C. The fan motor shall have permanently lubricated SRC bearings.

(3.4.3) Fan Blade

- A. The outdoor fan blade shall be a UL flame rated plastic-resin design.
- B. The fan blade shall be factory balanced in quiet performance and enhanced velocity.

(3.4.4) Compressor

- A. The compressor shall be a DC rotary type and A-PAM inverter-driven for stable operation in lower and higher frequency.
- B. The compressor shall be variable speed, variable capacity.
- C. The compressor shall have an internal overload protection device.
- D. The compressor shall use PVE (FV50S) refrigerant oil for better anti-wear effectiveness, superior resistance to capillary tube blockage and no hydrolysis compared to POE oil.

(3.4.5) 4WV

- A. The outdoor unit shall contain a four-way reversing valve (4WV) to change system mode from cool to heat.

(3.4.6) EEV

- A. The refrigerant flow shall be regulated by an electronic expansion valve (EEV).
- B. The outdoor control shall monitor the refrigerant flow through the EEV using a pulse-operated coil.
- C. The EEV shall maintain the target of 10°F (5.5°C) of superheat.

(3.4.7) Base Pan

- A. The base pan shall be constructed of commercial grade DC51/DC52 hot-dip galvanized steel with coating.
- B. The outdoor unit shall ship with a drain port adapter sized for 1/2 inch tubing to manage condensate run off.

(3.4.8) Copper Piping

- A. All internally connected copper tubing shall conform to ASTM B280 tubing tolerances.

(3.4.9) Outdoor Enclosure Materials

- A. The outdoor cabinet shall be constructed of commercial grade DC51/DC52 hot-dip galvanized steel with coating.

(3.4.10) Defrost

- A. The outdoor unit shall have a reverse-cycle (hot gas) defrost system to maximize heat pump operation and minimize energy consumption.

(3.4.11) Accumulator

- A. The accumulator shall be connected to the compressor return line to prevent liquid refrigerant from entering the compressor during operation.

4. HIGHWALL INDOOR UNITS

4.1 Dimensions

AW07TC2HDA
AW09TC2HDA
AW12TC2HDA



AW18TC2HDA

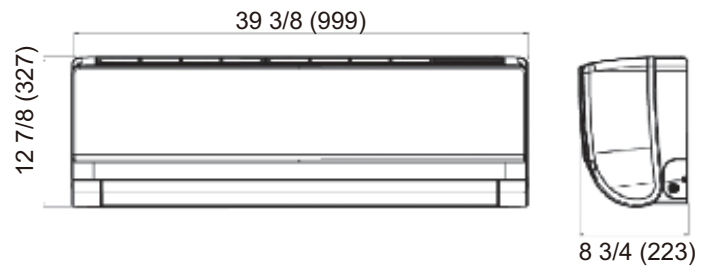

AW24TC2HDA

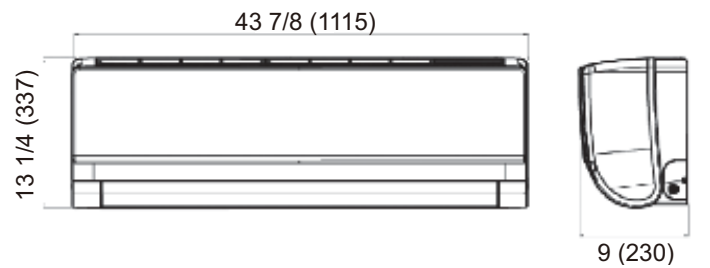

4.2 General

(4.2.1) Indoor Unit Description

A. The wall mounted indoor section completes the system when connected to the matching outdoor unit and field-supplied piping and wiring.

(4.2.2) Sound Ratings

A. Sound ratings as measured according to test standard JIS C 9612:

Model	Sound Pressure Level dB(A) (Turbo/High/Med/Low/Quiet)	Sound Power Level dB(A) (Turbo/High/Med/Low/Quiet)	Microphone Location
AW07TC2HDA	42/36/33/29/26	37/47/43/40/21	
AW09TC2HDA	42/36/33/29/26	37/47/43/40/21	
AW12TC2HDA	42/38/34/31/26	37/48/45/41/21	
AW18TC2HDA	48/45/42/39/36	43/53/50/47/31	
AW24TC2HDA	50/47/44/41/38	45/55/52/51/33	

(4.2.3) Warranty

A. The wall mounted indoor unit shall be covered by a manufacturer's parts warranty. (See Section 10. Limited Warranty)

4.3 Installation

(4.3.1) Condensate

- A. The wall mounted indoor shall be shipped with a insulated polyethylene condensate tubing (5/8" ID) attached from the factory.
- B. The wall mounted indoor unit shall ship with a 6.5 ft (2m) corrugated drain tube that connects to the insulated drain tube.
- C. The wall mounted indoor unit shall be a gravity drain.

(4.3.2) Clearances

- A. The installer must follow the minimum clearances illustrated in the Installation Manual when installing the indoor unit.

(4.3.3) Mounting

- A. The wall mounted indoor unit shall ship with a galvanized metal wall bracket.
- B. The wall bracket shall have multiple anchor points to provide the installer with many options to firmly attach the wall mounted indoor unit to the wall.
- C. The field-supplied mounting hardware must be sufficient to adequately support the indoor unit.



4.4 Electrical Requirements

(4.4.1) Electrical Disconnect

- A. Connecting wire must be continuous (without break) unless local code requires a disconnect at the indoor unit.

Model	Fan Motor Rating (HP)
AW07TC2HDA	.04
AW09TC2HDA	.04
AW12TC2HDA	.04
AW18TC2HDA	.054
AW24TC2HDA	.094

- B. If a disconnect is required by local code, it must be a 3-pole, single-throw type.



4.5 Components

(4.5.1) Coil

- A. The indoor coil shall be made with a blue colored hydrophilic coating on the aluminum fins and packed with internally grooved copper tubing, to increase the effective heat exchange surface area by 25%.
- B. Copper tubing shall have inner micro-grooves to increase effective heat transfer capabilities.
- C. Coils shall be pressure tested at 600~650 PSI using helium leak detection.
- D. The coil shall be charged with dry nitrogen for shipping at 70~100 PSI.

(4.5.2) Fan Motor

- A. The fan motor shall be a sealed DC multiple-speed resin-packed motor
- B. The fan motor shall have permanently lubricated bearings.

(4.5.3) Fan Blade

- A. The fan blade shall be a corrosion-resistant cross-flow blower.
- B. The fan shall be designed with optimized diameter and surface area to deliver quiet and even air flow.

Continued on following page...

4. HIGHWALL INDOOR UNITS

(4.5.4) Copper Piping

- A. The coil shall be connected to a length of insulated annealed copper.
- B. The ends of the tubing shall have male flare connections.

(4.5.5) Air Louvers

- A. The supply air shall be distributed by horizontal and vertical motorized louvers.
- B. Air Louvers shall provide wide angle of operation for both horizontal (120°) and vertical (90° from top to down) airflow movement to provide room comfort for each corner.

(4.5.6) Display

- A. The wall mounted indoor unit shall have a 4.5 x 1.1-inch backlit temperature display capable of showing set or room temperatures.
- B. The display shall also have colored icons representing set mode.
- C. The display can be turned off from the wireless remote control.

(4.5.7) WiFi

- A. Wall mounted indoor units shall come equipped with WiFi capabilities.

(4.5.8) Filter

- A. The wall mounted indoor unit shall have removable air filters.
- B. The air filters shall be washable and reusable.

(4.5.9) Control

- A. The wall mounted indoor unit shall ship with a hand-held infrared remote control (Standard Remote Control).
- B. The floor console indoor unit shall be compatible with the Standard Remote Control, Simplified Wired Controller and Programmable Wired Controller.
- C. The adapter, WK-B, must be used with the indoor unit when connected to a wired controller.

(4.5.10) Installation Clip

- A. The wall mounted indoor unit shall have a built-in clip that swings out and acts as a kick stand to allow for easier access to the rear of the unit during installation and repair.

5. MID-STATIC DUCTED INDOOR UNITS

5.1 Dimensions

USYM09UCDSA

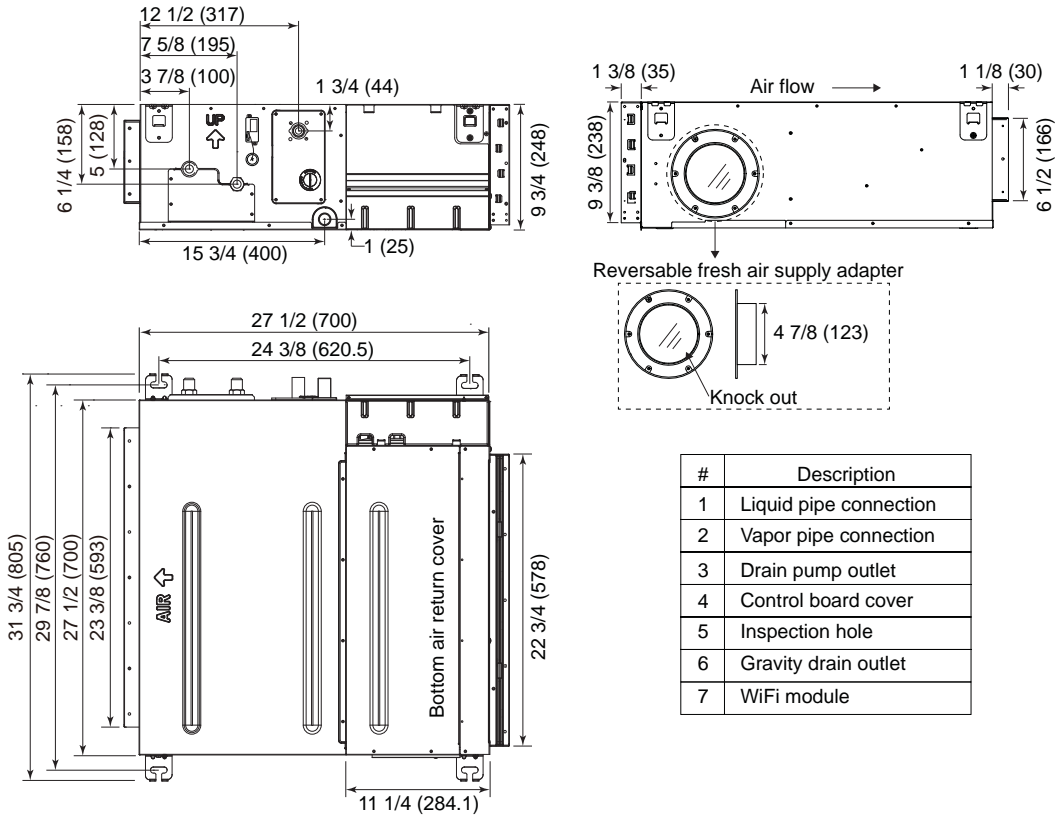

USYM12UCDSA

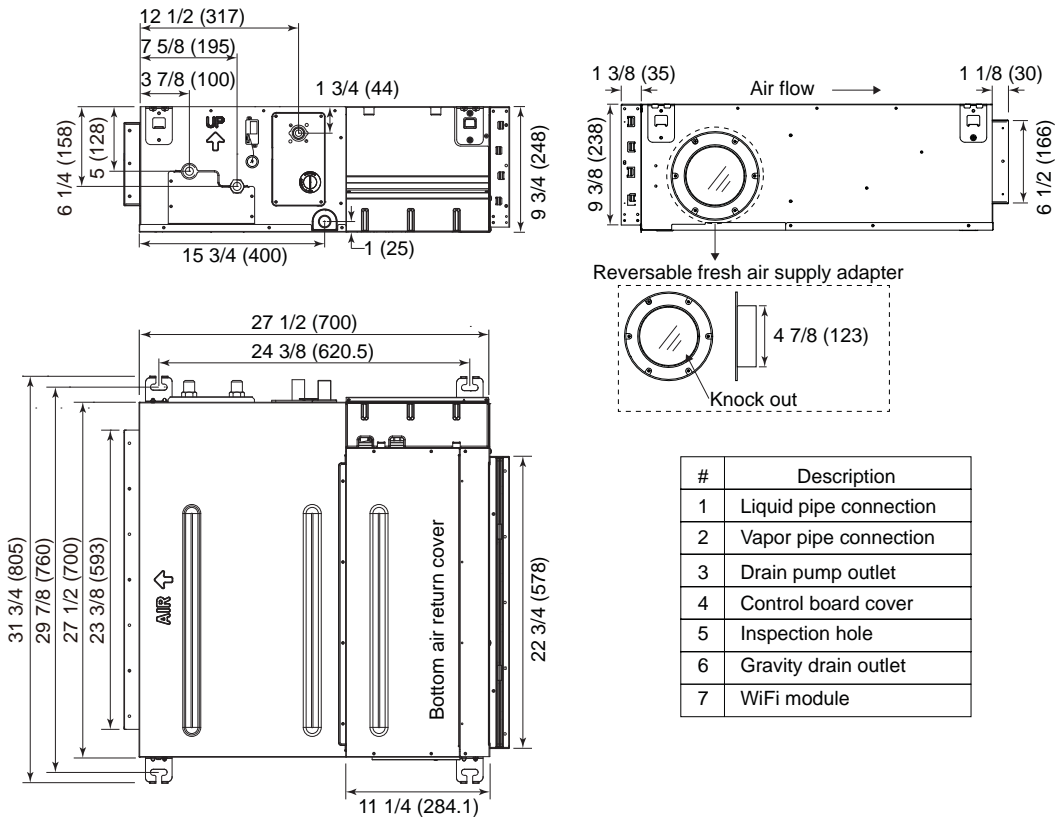

5. MID-STATIC DUCTED INDOOR UNITS

ENGLISH

USYM18UCDSA

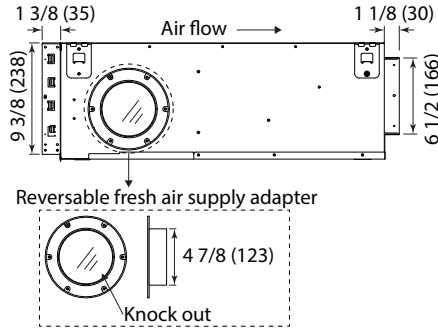
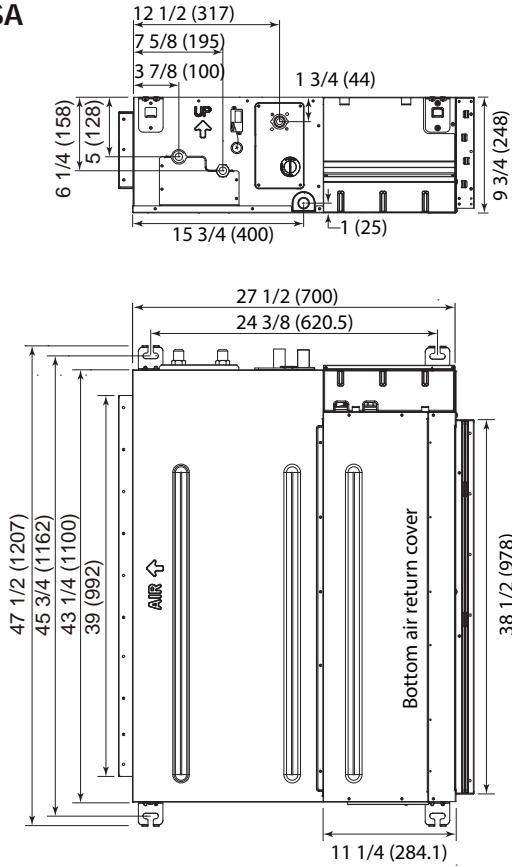

#	Description
1	Liquid pipe connection
2	Vapor pipe connection
3	Drain pump outlet
4	Control board cover
5	Inspection hole
6	Gravity drain outlet
7	WiFi module

USYM24UCDSA

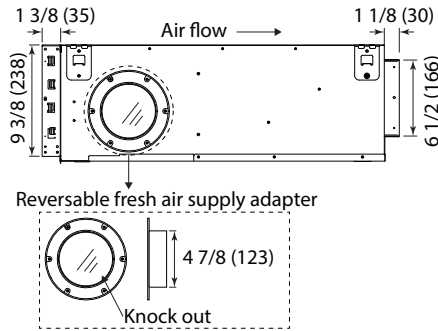
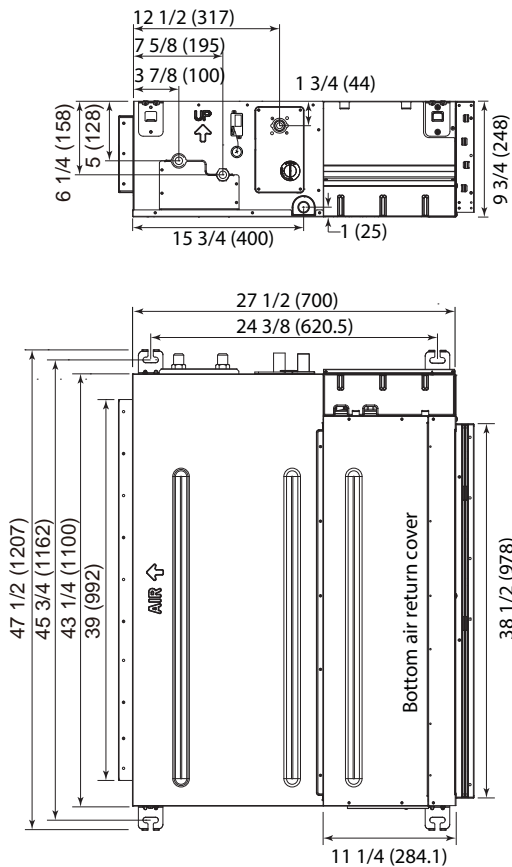

#	Description
1	Liquid pipe connection
2	Vapor pipe connection
3	Drain pump outlet
4	Control board cover
5	Inspection hole
6	Gravity drain outlet
7	WiFi module

5.2 General

(5.2.1) Indoor Unit Description

- A. The mid-static ducted indoor unit completes the system when connected to the matching outdoor unit and field-supplied piping and wiring.

(5.2.2) Sound Ratings

- A. Sound pressure rating as measured according to test standard JIS C 9612:

Model	Sound Pressure Level dB(A) (Turbo/High/Med/Low/Quiet)	Sound Power Level dB(A) (Turbo/High/Med/Low/Quiet)	Microphone Location
USYM09UCDSA	44/41/38/35/32	39/46/43/40/27	
USYM12UCDSA	47/44/41/38/35	42/49/46/43/30	
USYM18UCDSA	48/45/42/39/36	43/50/47/44/31	
USYM24UCDSA	50/48/45/42/39	45/53/50/47/34	

(5.2.3) Warranty

- A. The mid-static ducted indoor unit shall be covered by a manufacture parts warranty. (See Section **10. Limited Warranty**)

5.3 Installation

(5.3.1) Condensate

- A. The mid-static ducted indoor unit shall ship with an insulated drain tube adapter that is sized for 3/4-inch PVC on one end.
- B. The mid-static ducted indoor unit shall have a gravity drain port on one side of the unit.

(5.3.2) Clearances

- A. The installer must follow the minimum clearances illustrated in the installation manual when installing the indoor unit.

(5.3.3) Mounting

- A. The mid-static ducted indoor unit shall have 4 hanging brackets that are sized for 3/8 threaded rod.
- B. The installer must use 3/8 threaded rod to suspend the mid-static ducted indoor unit from the building structure.
- C. The installer must install the unit upright and level in all directions.

5.4 Electrical Requirements

(5.4.1) Electrical Disconnect

- A. Connecting wire must be continuous (without break) unless local code requires a disconnect at the indoor unit.

Model	Fan Motor Rating (HP)
USYM09UCDSA	.18
USYM12UCDSA	.18
USYM18UCDSA	.27
USYM24UCDSA	.27

- B. If a disconnect is required by local code, it must be a 3-pole, single-throw type.

5.5 Components

(5.5.1) Coil

- A. Coil shall be painted with a hydrophilic coating to increase airflow efficiency.
- B. Copper tubing shall have inner micro grooves to increase effective heat transfer capabilities.
- C. Coils shall be pressure tested at 600~650 PSI using Helium leak detection.
- D. The coil shall be charged with dry nitrogen for shipping at 70~100 PSI dwelling pressure.

(4.5.2) Fan Motor

- A. The ducted fan motor shall be a sealed DC resin-packed motor.
- B. The fan motor shall have permanently lubricated bearings

(4.5.3) Fan Blade

- A. The fan blade shall be a non-corrodible centrifugal fan blower.

(4.5.4) Copper Piping

- A. The coil shall be connected to a length of insulated annealed copper.
- B. The ends of the tubing shall have female flare connections.

(4.5.5) Filter

- A. The ducted indoor unit shall have removable air filters.
- B. The air filters shall be washable and reusable.

(4.5.6) Control

- A. The controller must be ordered separately.
- B. The ducted indoor unit shall be compatible with the standard remote control, simplified wired controller and programmable wired controller.

6. FLOOR CONSOLE INDOOR UNITS

6.1 Dimensions

USYF09UCDWA, USYF12UCDWA, USYF18UCDWA

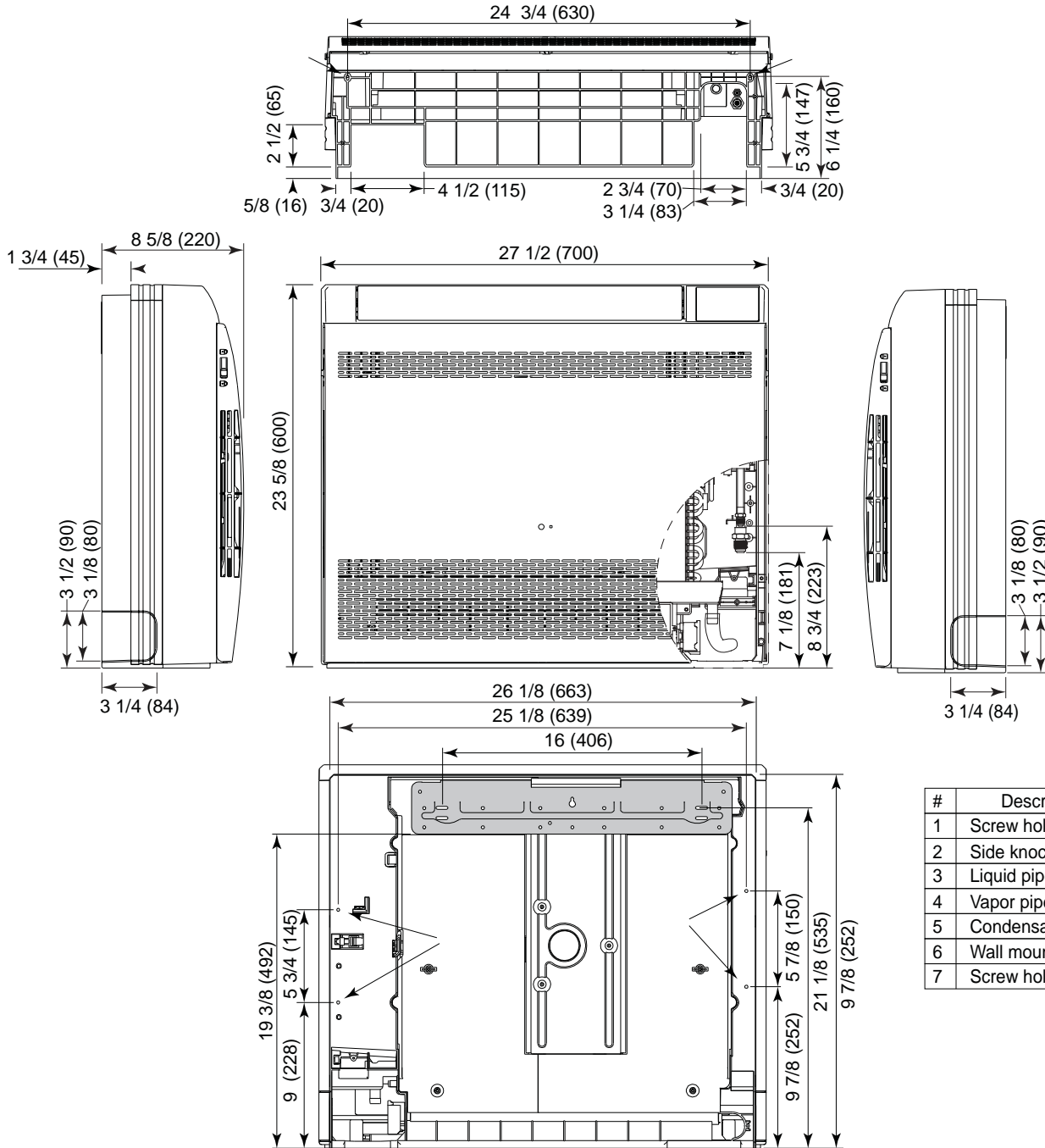

#	Description
1	Screw holes for floor install
2	Side knockout
3	Liquid pipe connection
4	Vapor pipe connection
5	Condensate drain
6	Wall mounting plate
7	Screw holes for wall install

6. FLOOR CONSOLE INDOOR UNITS

6.2 General

(6.2.1) Indoor Unit Description

- A. The floor console indoor section completes the system when connected to the matching outdoor unit and field-supplied piping and wiring.

(6.2.2) Sound Ratings

- A. Sound ratings as measured according to test standard JIS C 9612:

Model	Sound Pressure Level dB(A) (Turbo/High/Med/Low/Quiet)	Sound Power Level dB(A) (Turbo/High/Med/Low/Quiet)	Microphone Location
USYF09UCDWA	43/40/37/34/31	38/45/42/39/26	
USYF12UCDWA	45/42/39/36/33	40/47/44/41/28	
USYF18UCDWA	49/46/43/40/37	44/51/48/45/32	

(6.2.3) Warranty

- A. The floor console indoor unit shall be covered by a manufacture parts warranty. (See Section 10. Limited Warranty)

6.3 Installation

(6.3.1) Condensate

- A. The floor console indoor shall be shipped with a insulated polyethylene condensate tubing (5/8" ID) attached from the factory.
- B. The floor console indoor unit shall ship with a 6.5 ft (2m) corrugated drain tube that connects to the insulated drain tube.
- C. The floor console indoor unit shall be a gravity drain.

(6.3.2) Clearances

- A. The installer must follow the minimum clearances illustrated in the Installation Manual when installing the indoor unit.

(6.3.3) Mounting

- A. The floor console indoor unit may be installed on the floor or low on the wall.
- B. The floor console indoor unit shall ship with a galvanized metal wall bracket.
- C. The wall bracket shall have multiple anchor points to provide the installer with many options to firmly attach the wall mounted indoor unit to the wall.
- D. The field-supplied mounting hardware must be sufficient to adequately support the indoor unit.

6.4 Electrical Requirements

(6.4.1) Electrical Disconnect

- A. Connecting wire must be continuous (without break) unless local code requires a disconnect at the indoor unit.

Model	Fan Motor Rating (HP)
USYF09UCDWA	.04
USYF12UCDWA	.04
USYF18UCDWA	.04

- B. If a disconnect is required by local code, it must be a 3-pole, single-throw type.

6.5 Components

(6.5.1) Coil

- A. The indoor coil shall be made with a blue colored hydrophilic coating on the aluminum fins and packed with internally grooved copper tubing, to increase the effective heat exchange surface area by 25%.
- B. Copper tubing shall have inner micro-grooves to increase effective heat transfer capabilities.
- C. Coils shall be pressure tested at 600~650 PSI using helium leak detection.
- D. The coil shall be charged with dry nitrogen for shipping at 70~100 PSI.

(6.5.2) Fan Motor

- A. The fan motor shall be a sealed DC multiple-speed resin-packed motor
- B. The fan motor shall have permanently lubricated bearings.

(6.5.3) Fan Blade

- A. The fan blade shall be a noncorrodible axial fan blower.

(6.5.4) Copper Piping

- A. The coil shall be connected to a length of insulated annealed copper.
- B. The ends of the tubing shall have male flare connections.

(6.5.5) Air Louvers

- A. The supply air shall be distributed by horizontal and vertical motorized louvers.
- B. Air louvers shall provide wide angle of operation for both horizontal (120°) and vertical (90° from top to down) airflow movement to provide room comfort for each corner.

(6.5.6) Display

- A. The floor console indoor unit shall have a 1 x 5/8-inch backlit temperature display capable of showing set or room temperatures.
- B. The display shall also have colored icons representing set mode.
- C. The display can be turned off from the wireless remote control.

(6.5.7) WiFi

- A. Floor console indoor units shall come equipped with WiFi capabilities.

(6.5.8) Filter

- A. The floor console indoor unit shall have removable air filters.
- B. The air filters shall be washable and reusable.

(6.5.9) Control

- A. The floor console indoor unit shall ship with a hand-held infrared remote control (Standard Remote Control).
- B. The floor console indoor unit shall be compatible with the standard remote control, simplified wired controller and programmable wired controller

7. COMPACT CASSETTE INDOOR UNITS

7.1 Dimensions

AB09SC2VHA, AB12SC2VHA, AB18SC2VHA

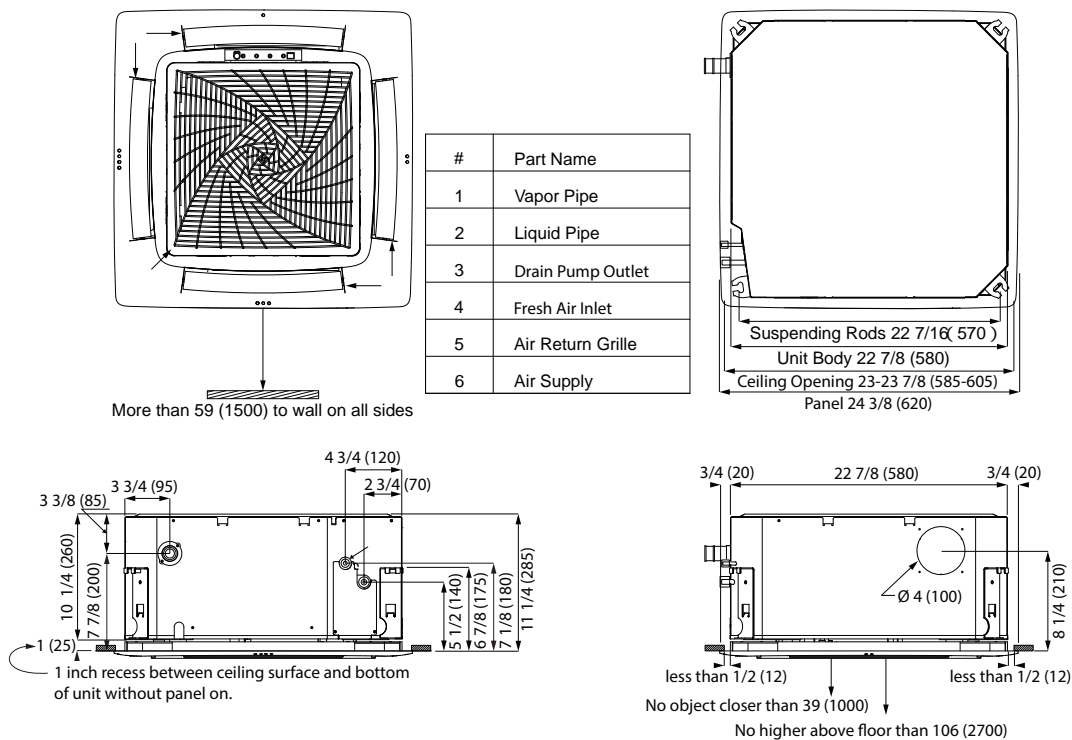

7.2 General

(7.2.1) Indoor Unit Description

A. The cassette indoor section completes the system when connected to the matching outdoor unit and field-supplied piping and wiring.

(7.2.2) Sound Ratings

A. Sound ratings as measured according to test standard JIS C 9612:

Model	Sound Pressure Level dB(A) (Turbo/High/Med/Low/Quiet)	Sound Power Level dB(A) (Turbo/High/Med/Low/Quiet)	Microphone Location
AB09SC2VHA	42/40/36/32/25	37/35/31/27/20	
AB12SC2VHA	42/40/36/32/25	37/35/31/27/20	
AB18SC2VHA	45/42/40/36/32	40/37/35/31/27	

(7.2.3) Warranty

A. The cassette indoor unit shall be covered by a manufacture parts warranty. (See Section 10. Limited Warranty)

7.3 Installation

(7.3.1) Condensate

- A. The cassette indoor unit shall ship with an insulated drain tube adapter that is sized for 3/4-inch PVC on one end.
- B. The cassette indoor unit shall be a gravity drain.

(7.3.2) Clearances

- A. The installer must follow the minimum clearances illustrated in the Installation Manual when installing the indoor unit.

(7.3.3) Mounting

- A. The cassette indoor unit shall have 4 hanging brackets that are sized for 3/8 threaded rod.
- B. The installer must use 3/8 threaded rod to suspend the cassette indoor unit from the building structure.
- C. The installer must install the unit upright and level in all directions.



7.4 Electrical Requirements

(7.4.1) Electrical Disconnect

- A. Connecting wire must be continuous (without break) unless local code requires a disconnect at the indoor unit.

Model	Fan Motor Rating (HP)
AB09SC2VHA	.033
AB12SC2VHA	.033
AB18SC2VHA	.033

- B. If a disconnect is required by local code, it must be a 3-pole, single-throw type.



7.5 Components

(7.5.1) Coil

- A. Coil shall be painted with a hydrophilic coating to increase airflow efficiency.
- B. Copper tubing shall have inner micro grooves to increase effective heat transfer capabilities.
- C. Coils shall be pressure tested at 600~650 PSI using Helium leak detection.
- D. The coil shall be charged with dry nitrogen for shipping at 70~100 PSI dwelling pressure.

(7.5.2) Fan Motor

- A. The fan motor shall be a sealed DC multiple-speed resin-packed motor
- B. The fan motor shall have permanently lubricated bearings.

(7.5.3) Fan Blade

- A. The fan blade shall be a noncorrodible axial fan blower.

(7.5.4) Copper Piping

- A. The coil shall be connected to a length of insulated annealed copper.
- B. The ends of the tubing shall have male flare connections.

(7.5.5) Panel

- A. A panel must be ordered separately.
- B. The cassette must be installed with a 1 inch recess beyond the ceiling surface to allow the panel to properly fit flush against the ceiling and to allow the panel gasket to seal against the cassette.

(7.5.6) Control

- A. The compact cassette indoor unit shall ship with a hand-held infrared remote control (Standard Remote Control).
- B. The compact cassette indoor unit shall be compatible with the Standard Remote Control, Simplified Wired Controller and Programmable Wired Controller.

7.6 Panel

PB-700IB 2x2 Compact Cassette Panel

(7.6.1) General

- A. The PB-700IB panel must be ordered separately when ordering the indoor cassette unit..

(7.6.2) Compatibility

- A. The PB-700IB panel shall be compatible Compact Cassette indoor units, AB09SC2VHA, AB12SC2VHA and AB18SC2VHA.

(7.6.3) Installation

- A. The cassette must be installed with a 1 inch recess beyond the ceiling surface to allow the panel to properly fit flush against the ceiling and to allow the panel gasket to seal against the cassette.

(7.6.4) Filter

- A. The cassette indoor unit shall have a removable air filter.
- B. The air filters shall be washable and reusable.

(7.6.5) Air Flow Control

- A. The PB-700IB shall have vertical and horizontal louvers on all side to direct the air flow.

8.1 Wireless Control

(8.1.1) General

- A. The standard remote control shall be compatible with floor console and cassette indoor units.
- B. The motion sense remote control shall be compatible with wall mounted indoor units.

(8.1.2) Connection

- A. Standard remote control shall be infrared.

(8.1.3) Compatibility

- A. The wireless control shall be compatible with all wall mounted, floor console and cassette indoor models.

(8.1.4) Warranty

- A. The warranty shall cover all defects in workmanship or material for a period of 1 year. A new or refurbished controller will provide with sole discretion.

(8.1.5) Features

- A. The standard remote control shall have a power button, individual mode buttons (heat, cool, dehumidify), temperature +/-, fan speed, vertical and horizontal louver adjust.
- B. The standard remote control shall be capable of setting a precise temperature of $\pm 1^{\circ}\text{f}$ ($\pm 0.5^{\circ}\text{C}$).
- C. The standard remote control shall have a backlight.
- D. The standard remote control shall have vertical and horizontal louver control.
- E. The standard remote control shall have a child lock function.
- F. The standard remote control shall have the ability to turn off/on the indoor unit display.
- G. The standard remote control shall have Fahrenheit and Celsius temperature functions.



8.2 Wired Controllers

(8.2.1) General

- A. The wired controller shall be a wall-mounted control that operates the indoor unit.

(8.2.2) Connection

- A. The wired controller shall connect to an indoor unit using the supplied 3-pin cable.
- B. 2 wired controls shall be connectible to one indoor unit.
- C. A single wired controller shall be able to connect up to 16 of the same model type of indoor units. The connected units shall work in unison as a single zone.

(8.1.3) Compatibility

- A. The wireless control shall be compatible with all indoor units.

(8.2.4) Warranty

- A. The warranty shall cover all defects in workmanship or material for a period of 1 year. A new or refurbished controller will provide with sole discretion.

(8.2.5) Simplified Wired Controller Features

- A. The wired controller shall have large physical buttons for easy operation.
- B. The wired controller shall have a power button, a mode button (heat, cool, dehumidify), a fan speed button, a temperature up button and a temperature down button.
- C. The wired controller shall be capable of setting a precise temperature of $\pm 1^{\circ}\text{F}$ ($\pm 0.5^{\circ}\text{C}$).
- D. The wired controller shall have a backlight.
- E. The wired controller shall have vertical and horizontal louver control.
- F. The wired controller shall have a child lock function.
- G. The wired controller shall display either Fahrenheit or Celsius.
- H. The wired controller shall have the ability to display indoor ambient temperature.
- I. The wired controller shall have a Clean Filter reminder.
- J. The wired controller shall display error codes.
- K. The wired controller shall have an infrared receiver that can receive commands from a hand-held remote control.

(8.2.6) Programmable Wired Controller Features

- A. The controller shall have a color display.
- B. The wired controller shall have a power button, individual mode buttons (heat, cool, dehumidify), temperature +/-, fan speed, vertical and horizontal louver adjustments.
- C. The wired controller shall be capable of setting a precise temperature of $\pm 1^{\circ}\text{F}$ ($\pm 0.5^{\circ}\text{C}$).
- D. The wired controller shall have a backlight.
- E. The wired controller shall have a child lock function.
- F. The wired controller shall display either Fahrenheit or Celsius.
- G. The wired controller shall have the ability to display indoor ambient temperature.
- H. The wired controller shall have a Clean Filter reminder.
- I. The wired controller shall display error codes.
- J. The wired controller shall be able to be programmed for daily or weekly settings. These settings can be for mode and temperature.

(8.2.7) QACT17A Features

- A. The wired controller shall have large physical buttons for easy operation.
- B. The wired controller shall have a power button, a mode button (heat, cool, dry), a fan speed button, a temperature up button and a temperature down button.
- C. The wired controller shall be capable of setting a precise temperature of $\pm 1^{\circ}\text{F}$ ($\pm 0.5^{\circ}\text{C}$).
- D. The wired controller shall have a backlight.
- E. The wired controller shall have vertical and horizontal louver control.
- F. The wired controller shall have a child lock function.
- G. The wired controller shall display either Fahrenheit or Celsius.
- H. The wired controller shall have the ability to display indoor ambient temperature.
- I. The wired controller shall have a Clean Filter reminder.
- J. The wired controller shall display error codes.
- K. The wired controller shall have an infrared receiver that can receive commands from a hand-held remote control.



8.3 Wi-Fi

(8.3.1) Features

- A. The Wi-Fi shall be Google Home compatible.
- B. The Wi-Fi shall be Amazon Alexa compatible.
- C. The homeowner shall have the ability to configure the Wi-Fi.

8.4 WK-B Interface Kit

(8.4.1) General

- A. The WK-B adapter shall be used when connecting a wired controller to a wall mounted indoor unit.

(8.4.2) Connection

- A. The WK-B adapter shall connect to the indoor unit with a supplied 3-wire cable.
- B. The wired controller shall connect to the WK-B with a supplied 3-wire cable.

(8.4.3) Compatibility

- A. The WK-B adapter shall be compatible with all mini-split and multi-split wall mounted indoor units.
- A. The WK-B adapter shall be compatible with simplified and programmable Haier wired controllers

(8.4.4) Warranty

- A. The warranty shall cover all defects in workmanship or material for a period of 1 year. A new or refurbished controller will provide with sole discretion.

Limited Warranty

For the product models listed on Attachment 1 (the "Product"), this Standard Base Limited Warranty is provided to the Original Owner of the Product:

For The Period Of:	GE Appliances Will Replace:
5 year limited parts warranty From the date of the original purchase	This Standard Base. Limited Warranty covers all defects in workmanship or material for the mechanical and electrical parts (including the compressor) contained in the Product ("Defective Parts") for a period of 5 years from the Date of Purchase. GE Appliances will provide new or refurbished parts, or a replacement for all or part of the unit, at its sole discretion, to your licensed HVAC technician installer. This warranty also covers all defects in workmanship or material for the unit controller for a period of 1 year. The remote controller is covered by 1-year accessory warranty. The ductless system is covered by Standard Base Limited Warranty. GE Appliances will provide a new or refurbished controller, at its sole discretion.

EXCLUDED COMPONENTS

The following components are not covered by this warranty: cabinets, cabinet pieces, air filters, driers, refrigerant, refrigerant line sets, belts, wiring, fuses, oil nozzles, unit accessories and any parts not affecting unit operation.

WHAT IS THE DATE OF PURCHASE

The "Date of Purchase" is the date that the original installation is complete and all product start-up procedures have been properly completed and verified by the installer's invoice. Registration is strongly recommended. If the installation date cannot be verified, then the Date of Purchase will be sixty (60) days after the manufacture date, as determined by the Product's serial number. You should keep and be able to provide your original sales receipt from the installer as proof of the Date of Purchase. For new construction, the Date of Purchase will be the date of purchase of the residence by the Owner from the builder.

WHO IS COVERED

Owner occupied: The "Original Owner" of this product means the original owner (and his or her spouse) of the residence where the Product was originally installed. Non-owner occupied: The "Original Owner" of the Product means the original owner of the building where the Product was originally installed, and for new construction, the purchaser of the building from the builder. "Non-owner occupied" is defined as a a) single family or multi-family non-owner-occupied residential building, or b) non-industrial commercial application, (such as office buildings, retail establishments, hotels/motels), but for non-owner-occupied Original Owners, this limited warranty requires that the product be installed and maintained annually by a licensed HVAC technician (proof of annual maintenance is required). Subject to the law of the state or province where the Product is installed, the remainder of this Standard Base Warranty is transferable to subsequent owners of the residence or building.

HOW CAN YOU GET SERVICE

Contact your licensed HVAC technician installer. All installation and service must be performed by a licensed HVAC technician. Failure to use a licensed HVAC technician for installation of this Product voids all warranty on this Product.

THIS WARRANTY DOES NOT COVER

- Damage from improper service or installation.
- Damage in shipping.
- Defects other than manufacturing defects (i.e., other than workmanship or materials).
- Damage from misuse, abuse, accident, alteration, lack of proper care and/or regular maintenance, or incorrect electrical voltage or current.
- Damage resulting from floods, fires, wind, lightning, accidents or similar conditions.
- Product that was not installed or serviced by a licensed HVAC technician.
- Labor and related services for repair or installation of the Product.
- A product purchased from an unauthorized online retailer.
- Damage as a result of subjecting Product to an atmosphere with corrosives or high levels of particulates (such as soot, aerosols, fumes, grease).
- A Product sold and/or installed outside of the 50 United States, the District of Columbia, or Canada.
- Batteries for the controller and other accessories provided with the Product for installation (e.g., plastic hose).
- Normal maintenance, such as cleaning of coils, cleaning filters, and lubrication.
- For Product installed in non-owner occupied applications, Product that has not been maintained annually by a licensed HVAC technician (proof required).
- Damage caused by a used or unapproved component or part by GE Appliances, a Haier company (e.g., a used and/or unapproved condenser / air handler).
- Component or parts are not provided by GE Appliances, a Haier Company
- Product that has been moved from its original installation to a new residence or building.

Continued on following page...

(Continued)

Limited Warranty

10 YEAR STANDARD REGISTERED LIMITED WARRANTY

All "Indoor and Outdoor Products," identified in Attachment 1, registered by the installer or the Original Owner within 60 days of the Date of Purchase shall receive a Standard Registered Limited Warranty, which shall be identical to the Standard Base Warranty, except that the Limited Parts Warranty shall be for a term of 10 Years. All Product not registered within 60 days of the Date of Purchase shall be subject to the Standard Base Warranty. Some states and provinces do not allow warranty terms to be subject to registration; in those states and provinces the longer terms for Limited Parts Warranty apply. Except in Texas or where otherwise required by law, this Standard Registered Limited Warranty is not transferable to a subsequent purchaser (other than the purchaser of a new building), but subsequent purchases will receive the remainder of the Standard Base Warranty.

THIS LIMITED WARRANTY IS GIVEN IN LIEU OF ALL OTHER WARRANTIES, EXPRESS OR IMPLIED, INCLUDING THE WARRANTIES OF MERCHANTABILITY AND FITNESS FOR A PARTICULAR PURPOSE.

The remedy provided in this warranty is exclusive and is granted in lieu of all other remedies. This warranty does not cover incidental or consequential damages. Some states and provinces do not allow the exclusion of incidental or consequential damages, so this limitation may not apply to you. Some states and provinces do not allow limitations on how long an implied warranty lasts, so this limitation may not apply to you. This warranty gives you specific legal rights and you may also have other rights which vary by state and province. This warranty covers units within the 50 United States, the District of Columbia and Canada. This warranty is provided by:

GE Appliances, a Haier company, Louisville, KY 40225.

ATTACHMENT 1

The "Product" is defined as Haier brand and GE Appliances brand Ductless Split Units and Side-discharge Units. The "Product" contains 2 sub-categories of goods: "Indoor and Outdoor Products" and "Selected Installation Products," which are further defined below: "Indoor and Outdoor Products" can further be identified by the following model number descriptions: 1U*, 2U*, 3U*, 4U*, 5U*, AB*, AD*, AL*, AM*, AW*, AF*, ASY*, USY*, ASH*, AUH*, UUC*, UUY*, "Selected Installation Products", identified by the following model number descriptions: PB-*, PAD-*.

[This page intentionally left blank.]

Haier



© Copyright 2024 GE Appliances, a Haier Company. Our continued commitment to quality products may mean a change in specifications without notice.