

Lighting Contactors

Contents

<i>Description</i>	<i>Page</i>
Open Control	
CN35 Electrically Held	37-2
C30CN Mechanically Held	37-8
A202 Magnetically Latched	37-17
UL Rated AC — Enclosed	
Product Family Overview	37-20
Non-combination C30CN Electrically and Mechanically Held	37-23
Non-combination CN35 Electrically Held	37-24
Non-combination A202 Magnetically Latched	37-26
Combination Electrically Held and Magnetically Latched	37-28
Wiring Diagrams	37-29
Modification Codes	37-33

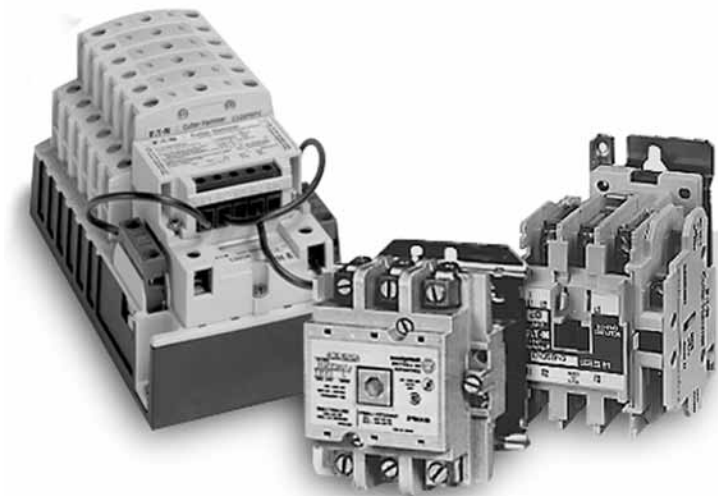

Mechanically Held, Magnetically Latched and Electrically Held Lighting Contactors

CN35 Electrically Held

Contents

<i>Description</i>	<i>Page</i>
Electrically Held	
Product Description	37-2
Application Description	37-2
Features	37-2
Instructional Leaflets	37-2
Standards and Certifications	37-2
Accessories	37-2
Renewal Parts	37-5
Dimensions	37-6
Product Selection	37-7

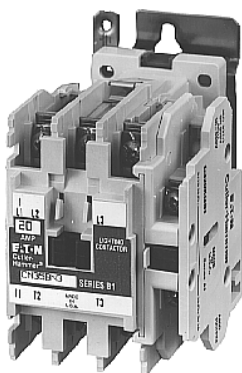

20A Cat. No. CN35BN3AB

Product Description

Cutler-Hammer® Type CN35 Electrically Held Lighting Contactors from Eaton's electrical business are designed to handle the switching of tungsten (incandescent) or ballast (fluorescent and mercury arc) lamp loads as well as other non-motor (resistive) loads.

Application Description

- Ideal applications include industrial plants, stadiums, parks and any new construction requiring lighting control.
- Ballast Lamps equate to Fluorescent, Mercury Vapor, Sodium Vapor and Quartz loads and will operate at a maximum of 600V.
- Filament Lamps equate to Incandescent, Infrared, Sodium Iodine and Heating loads and will operate at a maximum of 480V.
- Resistance Heating equates to radiant and convection heating, furnace and oven loads.

Features

- Designed and tested specifically for lighting and resistive loads
- Easy to install and maintain
- Full line of Freedom snap-on Accessories
- Standard with 1NO auxiliary contact (the 10A two- and three-pole ship standard with the auxiliary in the fourth power pole position with no increase in width)
- Top and side mounted auxiliary contacts available for 10 – 60A devices; side mounted auxiliaries only available on 100A and greater
- Straight-through wiring

Standards and Certifications

- UL File # E37317, Guide LR353
- CSA File # LR353



Accessories

Transient Suppressor Kits

10 – 60A Contactors



Cat. No. C320TS2

These kits limit high voltage transients produced in the control circuit when power is removed from the contactor or starter coil. There are three separate suppressors for use on 24 – 120V, 240V or 480V coils respectively.

These devices mount directly to the coil terminals of lighting contactors 10 – 60A.

Table 37-1. Kits for 10 – 60A

Description	Coil Voltage	Catalog Number	Price U.S. \$
Transient Suppressor	24 – 120V	C320TS1	
	240V	C320TS2	
	480V	C320TS3	

Instructional Leaflets

19225	CN35AN (2-, 3-, 4-Pole)
19227	CN35BN (2-, 3-Pole)
24829	CN35BN (4-, 5-Pole)
24840	CN35BN (6-, 9-, 12-Pole)
19227	CN35DN (2-, 3-Pole)
19229	CN35GN (2-, 3-Pole)
19874	CN35GN (4-, 5-Pole)
20218	CN35KN (2-, 3-Pole)
20171	CN35NN (2-, 3-Pole)
20172	CN35SN (2-, 3-Pole)
20172	CN35TN (2-, 3-Pole)

100 – 300A Contactors



Cat. No. C320AS1

This device mounts on top of any side mounted auxiliary contact on lighting contactors 100 – 300A. It connects across coil terminals on any 120V contactor magnet coil.

Limits high voltage transients produced in the circuit when power is removed from the coil.

Table 37-2. Kits for 100 – 300A

Description	Coil Voltage	Catalog Number	Price U.S. \$
Transient Suppressor	120V	C320AS1	

Discount Symbol **1CD-1C**

CN35 Electrically Held

Auxiliary Contacts

CN35 Lighting Contactors include a 1NO maintaining auxiliary contact mounted on right hand side (on 10A, 2- and 3-pole devices, auxiliary contact occupies 4th power pole position — no increase in width). The 10 – 60A devices will accept additional auxiliary contacts on the top and/or sides.

Auxiliary contact blocks are designed for snap-on installation — fast, easy installation (no tools required up to 60A). All auxiliary contacts are of the bifurcated design with parallel circuit paths. This redundant path provides very high reliability. Auxiliary contacts can be snapped on the side (up to 2 circuits — per auxiliary contact) and on the top (up to 4 circuits). Auxiliary contacts for larger contactors, 100 – 400A sizes, will accept side mounted auxiliaries only and easily attach to the side of the contactor with 2 screws.

**Auxiliary Contacts —
10 – 60A Contactors**



Side Mounted



Top Mounted

**Auxiliary Contacts —
100 – 400A Contactors**

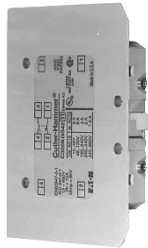

**Base Auxiliary Contact
Cat. No. C320KGS42**



**Auxiliary Contact
Cat. No. C320KGS22**

Contact Configuration Code

This 2-digit code is found on the auxiliary contact to assist in identifying the specific contact configuration. The first digit indicates the quantity of NO contacts and the second indicates the quantity of NC contacts.

Table 37-3. Auxiliary Contacts — 10 – 60A Contactors

Description	Contact Configuration Code ^①	Catalog Number	Price U.S. \$
Side Mounted			
1NO 1NC	10 01	C320KGS1 C320KGS2	
1NO-1NC 2NO 2NC	11 20 02	C320KGS3 C320KGS4 C320KGS5	
Top Mounted ^②			
1NO 1NC	10 01	C320KGT1 C320KGT2	
1NO-1NC 2NO 2NC	11 20 02	C320KGT3 C320KGT4 C320KGT5	
3NO 2NO-1NC 1NO-2NC 3NC 4NO	30 21 12 03 40	C320KGT9 C320KGT10 C320KGT11 C320KGT12 C320KGT13	
3NO-1NC 2NO-2NC 1NO-3NC 4NC	31 22 13 04	C320KGT14 C320KGT15 C320KGT16 C320KGT17	

^① For Reference Only — not part of Catalog Number. See below left.

^② Cannot be added to contactors or starters mounted in Box 1 (NEMA Type 1).

Table 37-4. Auxiliary Contacts — 100 – 400A Contactors

Circuit	Contact Configuration Code ^③	100A Contactors	200 & 300A Contactors	Price U.S. \$
		Catalog Number	Catalog Number	
Base Auxiliary Contacts — 100 – 400A Contactors				
NO NO-NC	10 11	C320KGS31 C320KGS32	C320KGS41 C320KGS42	
Circuit	Contact Configuration Code ^③	Catalog Number		Price U.S. \$
Auxiliary Contacts — 100 – 400A Contactors				
NO NC NO-NC ^④	10 01 11	C320KGS20 C320KGS21 C320KGS22		

^③ For Reference Only — not part of Catalog Number. See below left.

^④ NO-NC occupies two positions — L2 & L3 or R2 & R3. See Page 37-4.

Table 37-5. Auxiliary Contact Ratings (Amperes)

Current	AC Volts			
	120V	240V	480V	600V
NEMA A600				
Make & Interrupting	60.0	30.0	15.0	12.0
Break	6.0	3.0	1.5	1.0
Continuous	10.0	10.0	10.0	10.0
NEMA P300				
Continuous Thermal Rating: 5 Amperes				
DC Volts	Make/Break Amperes			
125	1.10			
250	0.55			

CN35 Electrically Held

Auxiliary Contact Location

Auxiliary Contacts — Mounting Positions

The sketches below illustrate the maximum number of auxiliary contacts that can be assembled to a contactor and their locations in standard enclosures.

Table 37-6. Auxiliary Contact Mounting Positions

Size	Poles	Available Mounting Positions ①②③		
		Open Type	NEMA 1	NEMA 3R, 4X, 12
10 Ampere	2 – 4	T1, L1, R1	L1	L1, T1
20 – 60 Ampere	2 – 3	T1, L1	L1	L1, T1
60 Ampere	4	T1, L1	—	L1, T1
60 Ampere	5	T1, L1	—	L1, T1
100 Ampere	2 – 3	R2, R3, L1, L2, L3	R2, R3, L1, L2, L3	R2, R3, L1, L2, L3
200 Ampere	2 – 3	R2, R3, L1, L2, L3	R2, R3, L1, L2, L3	R2, R3, L1, L2, L3
300 Ampere	2 – 3	R2, R3, L1, L2, L3	R2, R3, L1, L2, L3	R2, R3, L1, L2, L3
400 Ampere	2 – 3	R2, R3, L1, L2, L3	R2, R3, L1, L2, L3	R2, R3, L1, L2, L3

- ① Available positions on contactors or starters other than what is factory installed.
- ② When a pneumatic timer is mounted on contactor, only side mounted auxiliary contact positions are available. The solid-state timer, when added, takes up side mounted auxiliary contact position.
- ③ For 100 – 400A contactors, a base auxiliary contact must be added in position L1 before additional contacts can be mounted.

Pneumatic Timers — Top Mounted



Pneumatic Timer

Attachment mounts on top of 10 – 60A lighting contactors (top mounted auxiliary contacts can not be installed on device when timer is used). Timer unit has DPST timed contacts — circuits in each pole must be the same polarity. Units are convertible from OFF to ON Delay or vice-versa.

Table 37-7. Pneumatic Timers

Timing Range	Catalog Number	Price U.S. \$
.1 to 30 Seconds	C320TP1	
10 to 180 Seconds	C320TP2	

Table 37-8. Maximum Ampere Ratings

Description	Volts AC			
	120	240	480	600
Make	30.0	15.0	7.5	6.0
Break	3.0	1.5	0.75	0.6

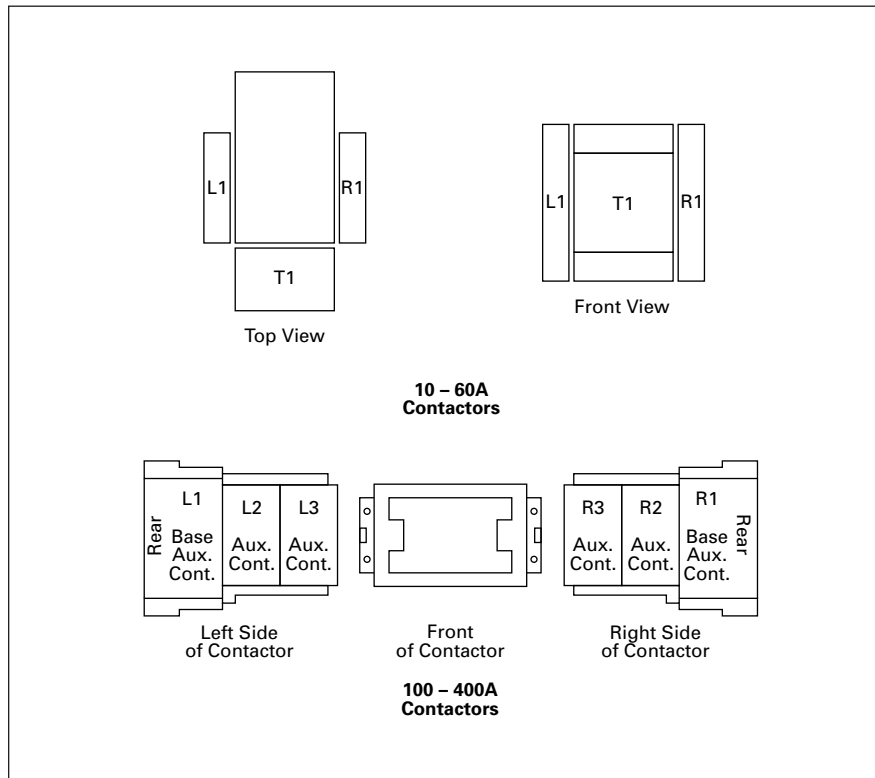

Figure 37-1. Auxiliary Contact Location

CN35 Electrically Held

Solid-State Timers

Solid-State ON DELAY Timer — Side Mounted on CN35 Freedom Series Lighting Contactors through 60A



This timer is designed to be **wired in SERIES with the load** (typically a coil). When the START button is pushed (power applied to timer), the ON DELAY timing function starts. At the completion of the set timing period, timer and series wired load will both be energized.

Table 37-9. Product Selection — Mounted Timer

Timing Range	Catalog Number ①②③	Price U.S. \$
.1 – 1.0 Seconds	C320TDN1_	
1 – 30 Seconds	C320TDN30_	
30 – 300 Seconds	C320TDN300_	
5 – 30 Minutes	C320TDN3000_	

- ① Add operating voltage Suffix to Catalog Number. **A** = 120V, **B** = 240V, **E** = 208V
- ② Rated .5 ampere pilot duty — not to be used on larger contactors.
- ③ Terminal connections are quick connects only. Two per side.

Renewal Parts

Table 37-10. Renewal Parts for CN35 Lighting Contactors

Description	10A	Price U.S. \$	20A, 30A	Price U.S. \$	60A	Price U.S. \$	100A	Price U.S. \$	200A	Price U.S. \$	300A	Price U.S. \$
	Series C1		Series C1		Series B1		Part No.		Part No.		Series B1	
	Part No.	Part No.	Part No.	Part No.	Part No.	Part No.						

Contact Kits

2-Pole	④		④		6-65-7		6-43-5		6-44		6-45	
3-Pole	④		④		6-65-8		6-43-6		6-44-2		6-45-2	
4-Pole	④		④		6-65-15		—		—		—	
5-Pole	④		④		6-65-16		—		—		—	

Magnet Coils

Coil Suffix

120V 60 Hz or 110V 50 Hz...	A	9-2875-1		9-2876-1		9-2703-1		9-2756-1		9-1891-1		9-1891-1
240V 60 Hz or 220V 50 Hz...	B	9-2875-2		9-2876-2		9-2703-2		9-2756-2		9-1891-2		9-1891-2
480V 60 Hz or 440V 50 Hz...	C	9-2875-3		9-2876-3		9-2703-3		9-2756-3		9-1891-3		9-1891-3
600V 60 Hz or 550V 50 Hz...	D	9-2875-4		9-2876-4		9-2703-4		9-2756-4		9-1891-4		9-1891-4
208V 60 Hz	E	9-2875-5		9-2876-5		9-2703-9		9-2756-5		9-1891-13		9-1891-13
277V 60 Hz	H	9-2875-12		9-2876-12		9-2703-7		9-2756-9		9-1891-26		9-1891-26
208/240V 60Hz	J	9-2875-37		9-2876-37		—		—		—		—
240V 50Hz	K	9-2875-11		9-2876-11		9-2703-14		9-2756-13		9-1891-20		9-1891-20
380 – 415V 50 Hz	L	9-2875-6		9-2876-6		9-2703-8		—		—		—
380V 50 Hz	L	—		—		—		9-2756-12		9-1891-14		9-1891-14
415V 50 Hz	M	—		—		—		9-2756-8		9-1891-21		9-1891-21
550V 50 Hz	N	—		—		—		9-2756-14	④	9-1891-8		9-1891-8
24V 60 Hz – 24V 50 Hz	T	9-2875-36		9-2876-36		—		—		—		—
24V 60 Hz	T	—		—		9-2703-6		9-2756-6		9-1891-15		9-1891-15
24V 50 Hz	U	9-2875-36		9-2876-13		9-2703-12		9-2756-11		9-1891-16		9-1891-16
32V 50 Hz	V	9-2875-16		9-2876-16		9-2703-10		9-2756-10		—		—
48V 60 Hz	W	9-2875-8		9-2876-8		9-2703-11		9-2756-15		—		—
48V 50 Hz	Y	9-2875-9		9-2876-9		9-2703-13		9-2756-7		9-1891-18		9-1891-18

④ Replace with complete contactor.

CN35 Electrically Held

Product Selection

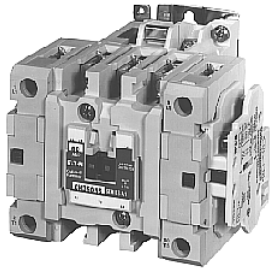

60A Cat. No. CN35GN5A

When Ordering Specify

- Catalog Number including the Coil Suffix Code from the Magnet Coil Selection Table.
- Any required Accessories.

Table 37-12. CN35 AC Lighting Contactors — Electrically Held

Maximum Ampere Rating ①	Number of Poles	Open Type	
		Catalog Number ③	Price U.S. \$
10	2	CN35AN2_B	
	3	CN35AN3_B	
	4	CN35AN4_B	
20	2	CN35BN2_B	
	3	CN35BN3_B	
	4	CN35BN4_B	
	6	CN35BN6_B	
	9	CN35BN9_B	
	12	CN35BN12_B	
30	2	CN35DN2_B	
	3	CN35DN3_B	
	4	CN35DN4_B	
	5	CN35DN5_B	
	6	CN35DN6_B	
	12	CN35DN12_B	
60	2	CN35GN2_B	
	3	CN35GN3_B	
	4 ②	CN35GN4_B	
	5 ②	CN35GN5_B	
100	2	CN35KN2_	
	3	CN35KN3_	
200	2	CN35NN2_	
	3	CN35NN3_	
300	2	CN35SN2_	
	3	CN35SN3_	
400 ④	2	CN35TN2_	
	3	CN35TN3_	

① The listed ampere ratings are based on a maximum load voltage of 480V for tungsten lamp applications and 600V for ballast or mercury vapor type applications.

② Additional power poles mounted on side(s) of contactor.

③ Underscore (_) indicates missing Code Letter for Magnet Coil — see Magnet Coil Selection table below.

④ UL ballast and resistive ratings only.

Table 37-13. Magnet Coil Selection

Coil Voltage and Hertz ⑦	Code Suffix	Coil Voltage and Hertz	Code Suffix	Coil Voltage and Hertz	Code Suffix	Coil Voltage and Hertz	Code Suffix
120/60 or 110/50	A	208/60	E	380 – 415/60	L	32/50	V
240/60 or 220/50	B	277/60	H	550/50	N	48/60	W
480/60 or 440/50	C	208 – 240/60 ⑤	J	24/60, 24/50 ⑥	T	48/50	Y
600/60 or 550/50	D	240/50	K	24/50	U		

⑤ For 10, 20 and 30A sizes only.

⑥ For 10, 20 and 30A sizes only. Sizes 60 – 400A are 24V/60 Hz only.

⑦ For **DC Magnet Coils**, see NEMA Contactors & Starters, **Pages 33-88 – 33-89**.

C30CN Mechanically Held

Contents

<i>Description</i>	<i>Page</i>
Open Control	
Product Description	37-8
Application Description . . .	37-8
Features	37-8
Operation	37-9
Instructional Leaflets	37-9
Standards and Certifications	37-9
Technical Data and Specifications	37-9
Components	37-10
Replacement Parts	37-11
Wiring Diagrams	37-12
Dimensions	37-14
Catalog Number Selection	37-14
Product Selection	37-15

37

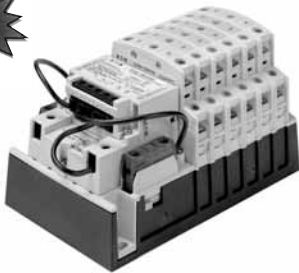

C30CNM

Product Description

The Cutler-Hammer® C30CNM 30A Mechanically Held Lighting Contactors from Eaton's electrical business are designed for industrial, commercial and outdoor lighting applications where efficient control is required. The mechanically held operation ensures that the contactor will not switch to OFF during control power failure. It also ensures the removal of coil from the circuit for noise-free operation and the elimination of all coil losses after the contactor is latched. The control module microprocessor validates the control signal before operation, so it will not respond to momentary voltage spikes of noise. The operation command has a built-in .4 sec delay to avoid multiple short-term commands that can cause contact fatigue or failure. Also, the feedback loop prevents the contactor from getting out of sequence with switches, even after power failures.

Application Description

The mechanically held lighting contactor provides effective control in applications such as office buildings, industrial plants, hospitals, stadiums, airports, etc.

They are ideal for applications that require quiet, energy-efficient operation.

Designed to handle different load types:

- Tungsten (incandescent filament)
- Ballast (fluorescent and mercury arc)
- High intensity discharge (HID)
- Non-motor AC resistive
- Single- and Three-Phase Motor Ratings

Features

See Figure 37-3.

- 30 amp power pole rating
- Up to 12 poles maximum
- Power poles latch easily onto the base, and designating them as NO or NC is a simple matter of left or right positioning. Additional poles, either NO or NC, may be easily added at any time.
- Low magnetic noise results in quiet operation
- Low input VA permits long wire runs
- Come in a wide range of input voltages and with coils from 24V to 277V AC and 12V to 24V DC.

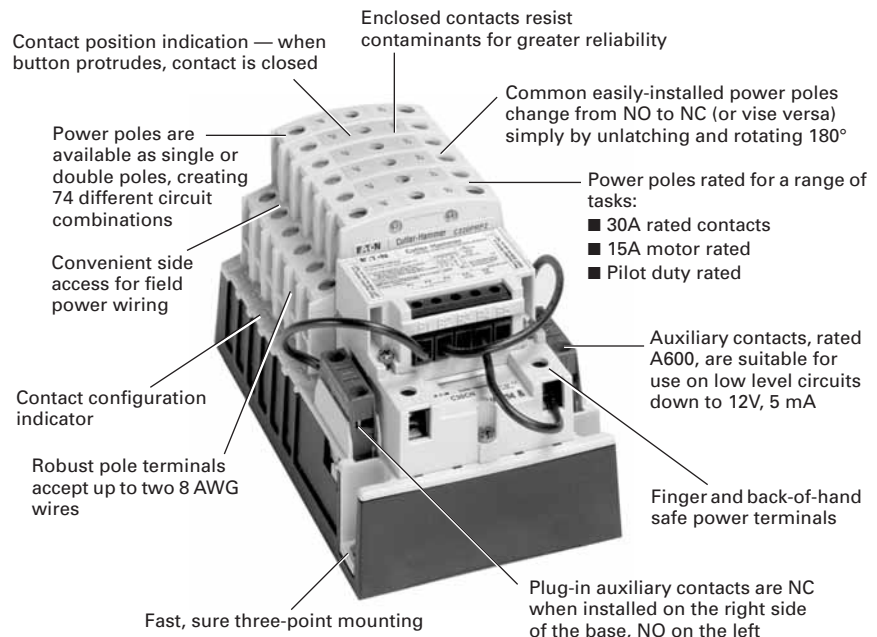

Figure 37-3. C30CNM Features

Operation

3-wire control is the choice for use with momentary devices allowing operation from multiple locations. A momentary pulse of energy operates the contactor while a second pulse on an alternate leg returns the contactor to its original state.

2-wire control is the choice for single output automatic operation or for operation from single-pole devices. When voltage is applied to the input terminals the contactor is latched into position (coil is removed from the circuit while control voltage is continuously supplied). When control voltage is removed, the latch is disengaged and the contactor is returned to its original state.

Instructional Leaflets

- 50765 C30CN Lighting Contactor Series
- 50766 Coil Kit for C30CN Lighting Contactors
- 50767 Power Pole Kit for C30CN Lighting Contactors
- 50768 Control Module Kit for C30CN Lighting Contactors

Standards and Certifications

- UL Listed File E1491, UL Category Code/Guide NLDX/NLDX7
- cUL
- CE



Technical Data and Specifications

Main Power Poles

Table 37-14. Maximum AC Voltage and Amp Ratings

Load Type	Amps Continuous	Poles	
		1-Phase	3-Phase
Ballast	30	347V AC	600V AC
General Use	30	600V AC	600V AC
Tungsten	20	277V AC	480V AC
AC Resistive	30	600V AC	600V AC

Table 37-15. Maximum Horsepower Rating

Normal Starting Duty	
1 Pole, Single-Phase	
Volts	Horsepower
110 – 120V	1
220 – 240V	2
3 Poles, Three-Phase	
Volts	Horsepower
200 – 208V	3
220 – 240V	5
440 – 480V	10
550 – 600V	15

Control Circuit Characteristics

Table 37-16. Coil

Description	VA
Inrush	248 VA
Sealed	28 VA

Table 37-17. Control Module

Input Voltage	Steady State Current @ Rated Voltage (mA)	Maximum VA
12 – 24V DC	42	2
24V AC	80	5
115 – 120V AC	83	12
200 – 277V AC	91	30

Table 37-18. Other Control Module Characteristics

Description	Specification
Minimum pulse duration (3-wire control module)	250 ms
Maximum allowable leakage current	1.8 mA
EMI	35 V/m
Surge transient peak	6 kV
Frequency Range	40 – 70 Hz

Auxiliary Contacts Rating:

A600, 24V DC, 24 VA

Ambient Temperature:

-13 to 104°F (-25 to 40°C)

Mounting Position:

Vertical 3-point mounting only.

Wire Size

Table 37-19. Wire Specifications

Component	Number of Cables	Wire Range (Solid or Stranded)	Wire Temperature
Power Poles	1	14 – 8 AWG	75°C Cu
	2	14 – 8 AWG ①	75°C Cu
Coil	1 or 2	18 – 14 AWG	60°/75°C Cu
Control Module	1	22 – 12 AWG	60°/75°C Cu
Auxiliary Contacts	1 or 2	22 – 12 AWG	60°/75°C Cu

① 8 AWG stranded only.

C30CN Mechanically Held

Components

Electrically Held Base Contactor

The C30CNE20_0 Electrically Held Base Contactor contains a 2NO power pole as standard and will allow the addition of power poles to build an Electrically Held Contactor up to 12 poles maximum. A Mechanically Held Module Kit can also be added to convert the Electrically Held Contactor into a Mechanically Held Contactor in the field.

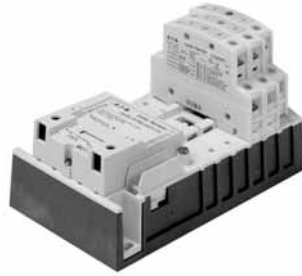

Electrically Held Base Contactor

Table 37-20. Electrically Held Base Contactor

Power Poles	Catalog Number ①	Price U.S. \$
2NO	C30CNE20_0	

① When ordering, select required contactor by Catalog Number and replace the magnet coil alpha designation in the Catalog Number () with the proper Code Suffix from Table 37-21.

Table 37-21. Coil Base Voltage (Digit 8)

Voltage (Digit 8)	Code Suffix
115 – 120V 60 Hz/110V 50 Hz	A
230 – 240V 60 Hz/220V 50 Hz	B
460 – 480V 60 Hz/440V 50 Hz	C
575 – 600V 60 Hz/550V 50 Hz	D
200 – 208V 60 Hz	E
265 – 277V 60 Hz/240V 50 Hz	H
24V 60 Hz/20V 50 Hz	T
28V 60 Hz/24V 50 Hz	V
347V 60 Hz	X

Power Poles



Power Poles

The C30CNM contactor accepts up to a maximum 6 single- or double-pole (or combinations) power poles. These can be used to form up to:

- 12 NO poles max. when 6 double-poles are used in NO positions (1 – 6) or
- 8 NC poles max. with 4 double-poles in the NC position (1 – 4) and 4 NO poles with 2 double-poles in the 2 NO positions (5 – 6)

Table 37-22. Power Poles

Power Poles	Catalog Number	Price U.S. \$
Single-Pole	C320PRP1	
Double-Pole	C320PRP2	

Mechanically Held Module Kits

These kits are for converting electrically held contactors to mechanically held units. Kits include control module, latch, latch cover and auxiliary contacts plus installation instructions. Conversion kits are suitable for coil voltages of 277V and below.



Conversion Kits

Table 37-23. Mechanically Held Module Kits

Coil Volts	Control Volts	Catalog Number	Price U.S. \$
2-Wire			
24 – 277V AC	110 – 120V AC	C320MH2WA0	
	200 – 277V AC	C320MH2WH0	
	24V AC	C320MH2WT0	
	12 – 24V DC	C320MH2WT1	
3-Wire			
24 – 277V AC	110 – 120V AC	C320MH3WA0	
	200 – 277V AC	C320MH3WH0	
	24V AC	C320MH3WT0	
	12 – 24V DC	C320MH3WT1	

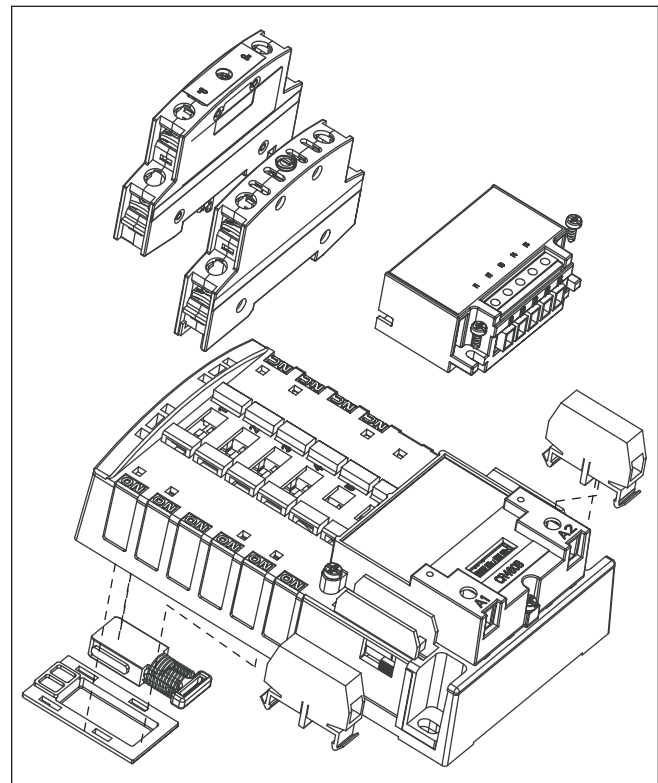

Figure 37-4. C30CNM Components — Exploded View

Discount Symbol 1CD-1C

Auxiliary Contacts

A Mechanically Held Contactor with a 2-wire control module uses 1NC auxiliary contact as standard for the control wiring circuit. The Mechanically Held Contactor with a 3-wire control module uses 1NO-1NC auxiliary contacts as standard for the control wiring circuit. See **Table 37-24** for possible additional auxiliary contact configurations.

Table 37-24. Auxiliary Contact Configurations

2-Wire	3-Wire
None 1NO (single-pole) 2NO (double-pole) 1NC (double-pole) 1NO-1NC (NO single pole, NC double-pole) 2NO-1NC (double-pole)	1NC (double-pole) 1NO (double-pole) 1NO-1NC (double-pole)



Auxiliary Contacts

Table 37-25. Auxiliary Contacts

Auxiliary Block	Catalog Number	Price U.S. \$
Single-Pole	C320AMH1	
Double-Pole	C320AMH2	

Replacement Parts

Magnet Coils for the Base Contactor



Magnetic Coils

Table 37-26. Magnetic Coils

Coil Voltage	Catalog Number	Price U.S. \$
115 – 120V 60 Hz/110V 50 Hz	9-3242-1	
230 – 240V 60 Hz/220V 50 Hz	9-3242-2	
460 – 480V 60 Hz/440V 50 Hz	9-3242-3	
575 – 600V 60 Hz/550V 50 Hz	9-3242-4	
200 – 208V 60 Hz	9-3242-5	
265 – 277V 60 Hz/240V 50 Hz	9-3242-6	
24V 60 Hz/20V 50 Hz	9-3242-7	
28V 60 Hz/24V 50 Hz	9-3242-8	
347V 60 Hz	9-3242-9	

Wiring Diagrams

37

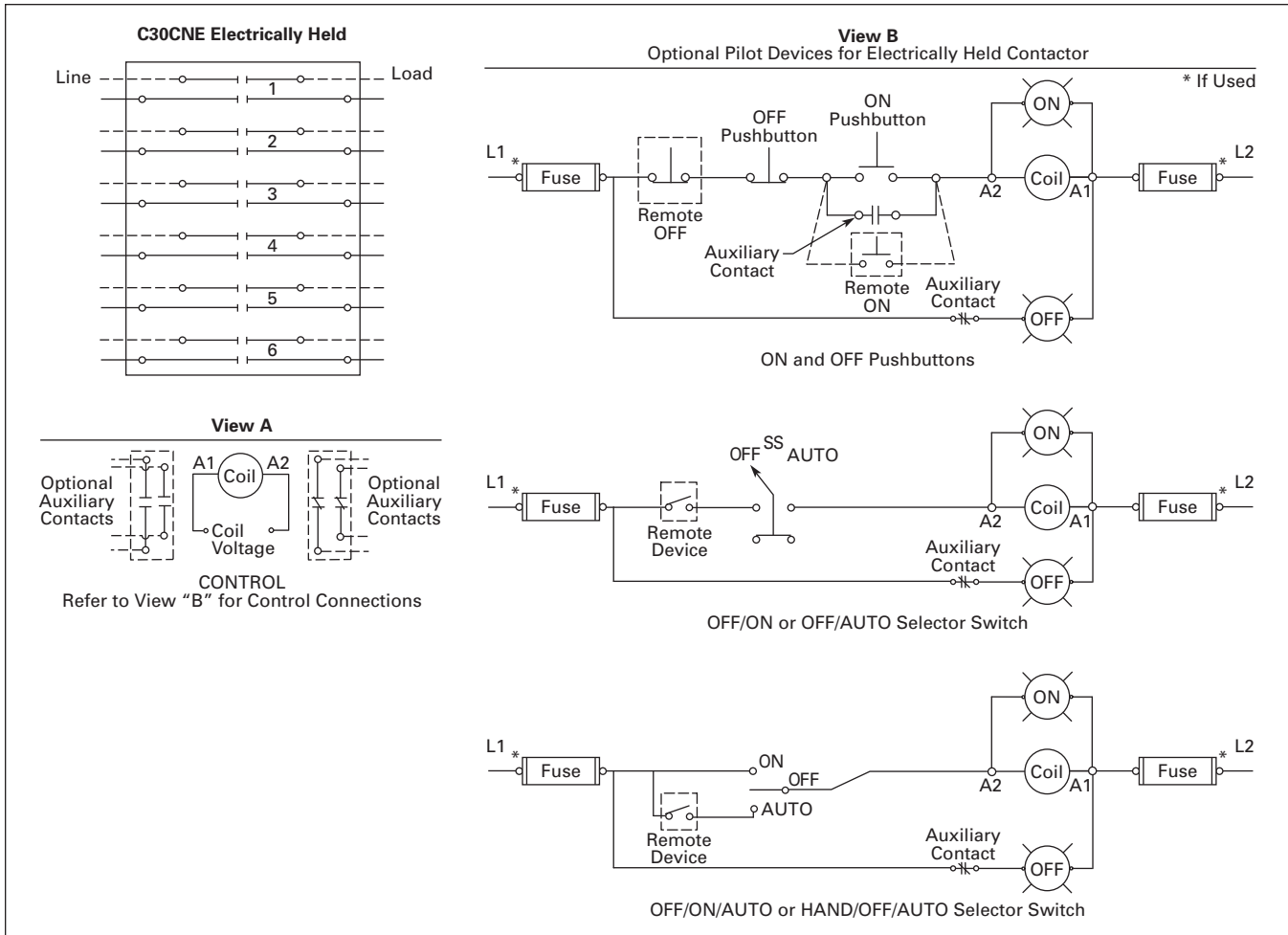

Figure 37-5. C30CNE Wiring Diagrams

C30CN Mechanically Held

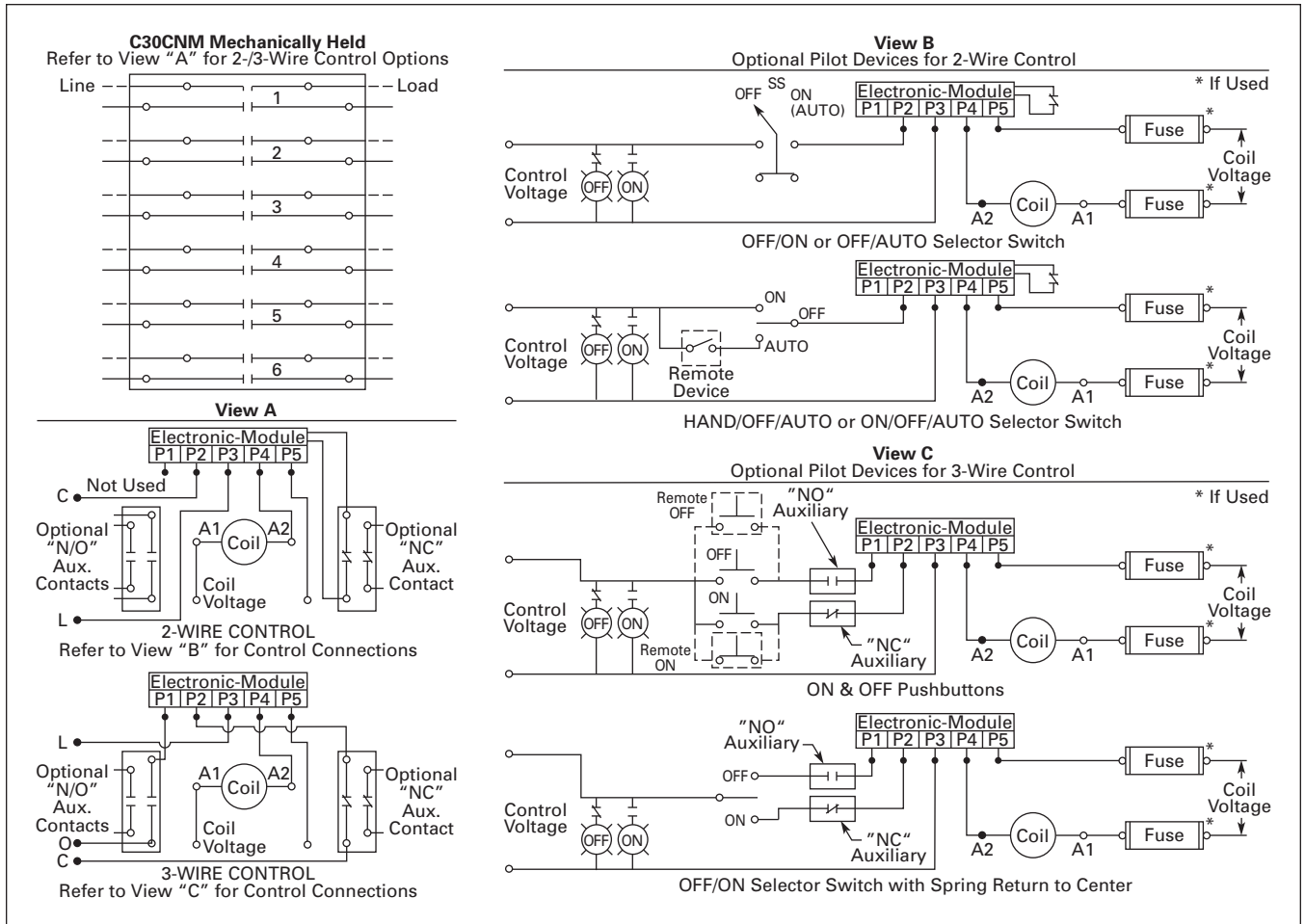
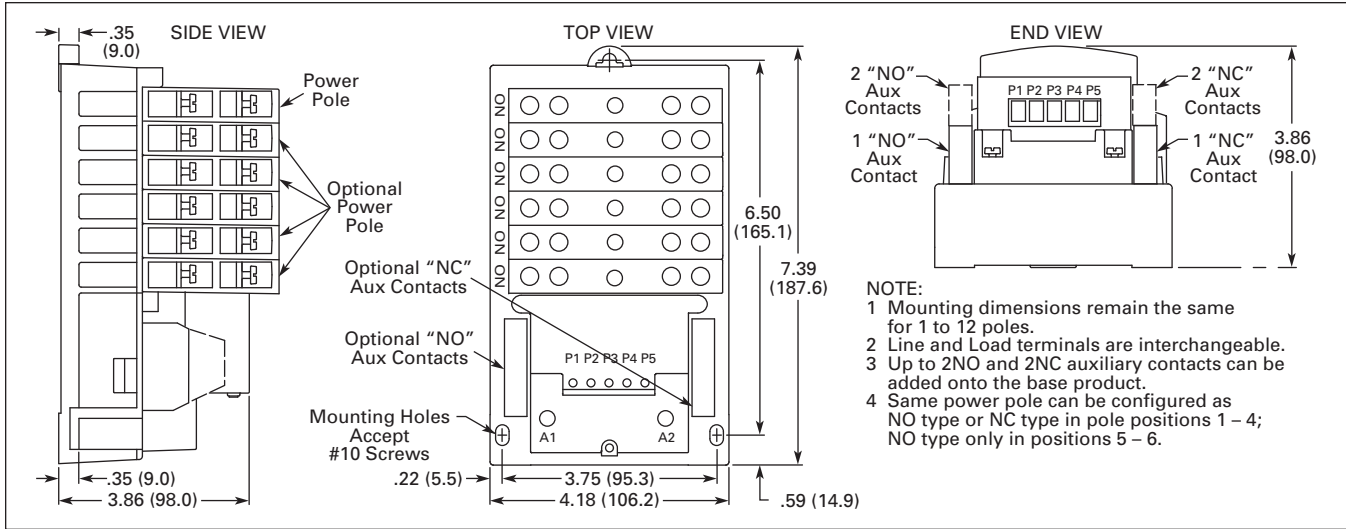

Figure 37-6. C30CNM Wiring Diagrams

C30CN Mechanically Held

Dimensions



- NOTE:
- 1 Mounting dimensions remain the same for 1 to 12 poles.
 - 2 Line and Load terminals are interchangeable.
 - 3 Up to 2NO and 2NC auxiliary contacts can be added onto the base product.
 - 4 Same power pole can be configured as NO type or NC type in pole positions 1 – 4; NO type only in positions 5 – 6.

Figure 37-7. Approximate Dimensions in Inches (mm)

Catalog Number Selection

Table 37-27. Type C30CN Lighting Contactors — Catalog Numbering System

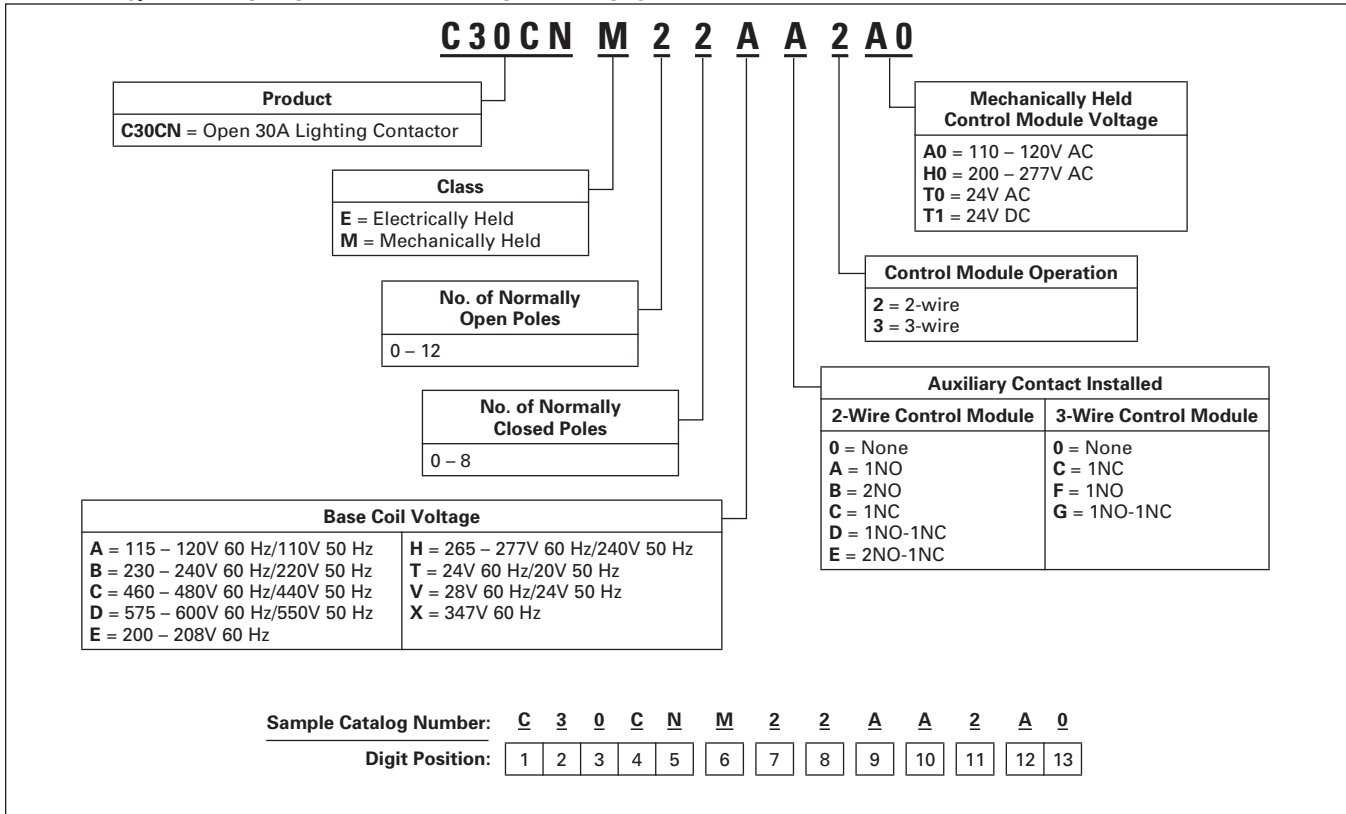

Product Selection

2-Wire Mechanically Held Lighting Contactors — Standard Assembled Forms

The Standard Assembled Forms in **Table 37-28** are 2-wire open mechanically held 30 amp lighting contactors with 120V 60 Hz/ 110V 50 Hz base coil voltage, 120V control module voltage, and no additional auxiliary contacts. To change the base coil voltage, auxiliary contact options or control module voltage, refer to **Tables 37-29, 37-30** and **37-31** respectively.

Table 37-28. 2-Wire Mechanically Held Lighting Contactors — Standard Assembled Forms Product Selection

No. of Poles	NO	NC	Catalog Number ①②③	Price U.S. \$
2	0	2	C30CNM02A02A0	
	1	1	C30CNM11A02A0	
	2	0	C30CNM20A02A0	
3	0	3	C30CNM03A02A0	
	1	2	C30CNM12A02A0	
	2	1	C30CNM21A02A0	
	3	0	C30CNM30A02A0	
4	0	4	C30CNM04A02A0	
	1	3	C30CNM13A02A0	
	2	2	C30CNM22A02A0	
	3	1	C30CNM31A02A0	
	4	0	C30CNM40A02A0	
5	0	5	C30CNM05A02A0	
	1	4	C30CNM14A02A0	
	2	3	C30CNM23A02A0	
	3	2	C30CNM32A02A0	
	4	1	C30CNM41A02A0	
	5	0	C30CNM50A02A0	
6	0	6	C30CNM06A02A0	
	1	5	C30CNM15A02A0	
	2	4	C30CNM24A02A0	
	3	3	C30CNM33A02A0	
	4	2	C30CNM42A02A0	
	5	1	C30CNM51A02A0	
	6	0	C30CNM60A02A0	
7	0	7	C30CNM07A02A0	
	1	6	C30CNM16A02A0	
	2	5	C30CNM25A02A0	
	3	4	C30CNM34A02A0	
	4	3	C30CNM43A02A0	
	5	2	C30CNM52A02A0	
	6	1	C30CNM61A02A0	
	7	0	C30CNM70A02A0	
8	0	8	C30CNM08A02A0	
	1	7	C30CNM17A02A0	
	2	6	C30CNM26A02A0	
	3	5	C30CNM35A02A0	
	4	4	C30CNM44A02A0	
	5	3	C30CNM53A02A0	
	6	2	C30CNM62A02A0	
	7	1	C30CNM71A02A0	
	8	0	C30CNM80A02A0	
9	1	8	C30CNM18A02A0	
	2	7	C30CNM27A02A0	
	3	6	C30CNM36A02A0	
	4	5	C30CNM45A02A0	
	5	4	C30CNM54A02A0	
	6	3	C30CNM63A02A0	
	7	2	C30CNM72A02A0	
	8	1	C30CNM81A02A0	
	9	0	C30CNM90A02A0	
	10	2	8	
3		7	C30CNM37A02A0	
4		6	C30CNM46A02A0	
5		5	C30CNM55A02A0	
6		4	C30CNM64A02A0	
7		3	C30CNM73A02A0	
8		2	C30CNM82A02A0	
9		1	C30CNM91A02A0	
10		0	C30CNM100A02A0	

No. of Poles	NO	NC	Catalog Number ①②③	Price U.S. \$
11	3	8	C30CNM38A02A0	
	4	7	C30CNM47A02A0	
	5	6	C30CNM56A02A0	
	6	5	C30CNM65A02A0	
	7	4	C30CNM74A02A0	
	8	3	C30CNM83A02A0	
	9	2	C30CNM92A02A0	
12	10	1	C30CNM101A02A0	
	11	0	C30CNM110A02A0	
	4	8	C30CNM48A02A0	
	6	6	C30CNM66A02A0	
	8	4	C30CNM84A02A0	
12	10	2	C30CNM102A02A0	
	12	0	C30CNM120A02A0	

- ① To change the base coil voltage, replace the content of Position 9 with the appropriate Code Suffix from **Table 37-29**.
- ② To change auxiliary contact options, replace the content of Position 10 with the appropriate Code Suffix from **Table 37-30**.
- ③ To change the control module voltage, replace the content of Positions 12-13 with the appropriate Code Suffix from **Table 37-31**.

Table 37-29. Base Coil Voltage (Digit 9)

Voltage	Code Suffix	Adder U.S. \$
115 – 120V 60 Hz/110V 50 Hz	A	
230 – 240V 60 Hz/220V 50 Hz	B	
460 – 480V 60 Hz/440V 50 Hz	C	
575 – 600V 60 Hz/550V 50 Hz	D	
200 – 208V 60 Hz	E	
265 – 277V 60 Hz/240V 50 Hz	H	
24V 60 Hz/20V 50 Hz	T	
28V 60 Hz/24V 50 Hz	V	
347V 60 Hz	X	

Note: If coil supply is greater than 277V, use CPT.

Table 37-30. Auxiliary Contact Installed (Digit 10)

Control Module	Circuit	Code Suffix	Adder U.S. \$
2-wire	None	0	
	1NO	A	
	2NO	B	
	1NC	C	
	1NO-1NC	D	
	2NO-1NC	E	

Table 37-31. Control Module Voltage (Digit 12-13)

Coil Module	Code Suffix	Adder U.S. \$
110 – 120V AC	A0	
200 – 277V AC	H0	
24V AC	T0	
12 – 24V DC	T1	

C30CN Mechanically Held

3-Wire Mechanically Held Lighting Contactors — Standard Assembled Forms

The Standard Assembled Forms in Table 37-32 are 3-wire open mechanically held 30 amp lighting contactors with 120V 60 Hz/110V 50 Hz base coil voltage, 120V control module voltage, and no additional auxiliary contacts. To change the base coil voltage, auxiliary contact options or control module voltage, refer to Tables 37-33, 37-34 and 37-35 respectively.

Table 37-32. 3-Wire Mechanically Held Lighting Contactors — Standard Assembled Forms Product Selection

No. of Poles	NO	NC	Catalog Number ①②③	Price U.S. \$
2	0	2	C30CNM02A03A0	
	1	1	C30CNM11A03A0	
	2	0	C30CNM20A03A0	
3	0	3	C30CNM03A03A0	
	1	2	C30CNM12A03A0	
	2	1	C30CNM21A03A0	
	3	0	C30CNM30A03A0	
4	0	4	C30CNM04A03A0	
	1	3	C30CNM13A03A0	
	2	2	C30CNM22A03A0	
	3	1	C30CNM31A03A0	
5	0	5	C30CNM05A03A0	
	1	4	C30CNM14A03A0	
	2	3	C30CNM23A03A0	
	3	2	C30CNM32A03A0	
	4	1	C30CNM41A03A0	
6	0	6	C30CNM06A03A0	
	1	5	C30CNM15A03A0	
	2	4	C30CNM24A03A0	
	3	3	C30CNM33A03A0	
	4	2	C30CNM42A03A0	
	5	1	C30CNM51A03A0	
7	0	7	C30CNM07A03A0	
	1	6	C30CNM16A03A0	
	2	5	C30CNM25A03A0	
	3	4	C30CNM34A03A0	
	4	3	C30CNM43A03A0	
	5	2	C30CNM52A03A0	
	6	1	C30CNM61A03A0	
8	0	8	C30CNM08A03A0	
	1	7	C30CNM17A03A0	
	2	6	C30CNM26A03A0	
	3	5	C30CNM35A03A0	
	4	4	C30CNM44A03A0	
	5	3	C30CNM53A03A0	
	6	2	C30CNM62A03A0	
	7	1	C30CNM71A03A0	
9	0	8	C30CNM08A03A0	
	1	7	C30CNM17A03A0	
	2	6	C30CNM26A03A0	
	3	5	C30CNM35A03A0	
	4	4	C30CNM44A03A0	
	5	3	C30CNM53A03A0	
	6	2	C30CNM62A03A0	
	7	1	C30CNM71A03A0	
	8	0	C30CNM80A03A0	
10	2	8	C30CNM28A03A0	
	3	7	C30CNM37A03A0	
	4	6	C30CNM46A03A0	
	5	5	C30CNM55A03A0	
	6	4	C30CNM64A03A0	
	7	3	C30CNM73A03A0	
	8	2	C30CNM82A03A0	
	9	1	C30CNM91A03A0	
	10	0	C30CNM100A03A0	

No. of Poles	NO	NC	Catalog Number ①②③	Price U.S. \$		
11	3	8	C30CNM38A03A0			
	4	7	C30CNM47A03A0			
	5	6	C30CNM56A03A0			
	6	5	C30CNM65A03A0			
	7	4	C30CNM74A03A0			
	8	3	C30CNM83A03A0			
	9	2	C30CNM92A03A0			
	10	1	C30CNM101A03A0			
	11	0	C30CNM110A03A0			
	12	4	8		C30CNM48A03A0	
		6	6		C30CNM66A03A0	
8		4	C30CNM84A03A0			
10		2	C30CNM102A03A0			
12		0	C30CNM120A03A0			

- ① To change the base coil voltage, replace the content of Position 9 with the appropriate Code Suffix from Table 37-33.
- ② To change auxiliary contact options, replace the content of Position 10 with the appropriate Code Suffix from Table 37-34.
- ③ To change the control module voltage, replace the content of Positions 12-13 with the appropriate Code Suffix from Table 37-35.

Table 37-33. Base Coil Voltage (Digit 9)

Voltage	Code Suffix	Adder U.S. \$
115 – 120V 60 Hz/110V 50 Hz	A	
230 – 240V 60 Hz/220V 50 Hz	B	
460 – 480V 60 Hz/440V 50 Hz	C	
575 – 600V 60 Hz/550V 50 Hz	D	
200 – 208V 60 Hz	E	
265 – 277V 60 Hz/240V 50 Hz	H	
24V 60 Hz/20V 50 Hz	T	
28V 60 Hz/24V 50 Hz	V	
347V 60 Hz	X	

Note: If coil supply is greater than 277V, use CPT.

Table 37-34. Auxiliary Contact Installed (Digit 10)

Control Module	Circuit	Code Suffix	Adder U.S. \$
3-wire	None	0	
	1NC	C	
	1NO	F	
	1NO-1NC	G	

Table 37-35. Control Module Voltage (Digit 12-13)

Coil Module	Code Suffix	Adder U.S. \$
110 – 120V AC	A0	
200 – 277V AC	H0	
24V AC	T0	
12 – 24V DC	T1	

A202 Magnetically Latched

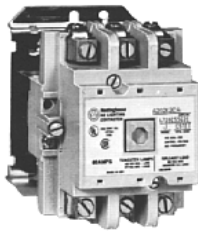

60A Size

Product Description

The Cutler-Hammer® A202 Lighting Contactor from Eaton's electrical business provides a safe and convenient means for local or remote switching of relatively large tungsten, fluorescent or mercury arc lamp loads.

Application Description

- The Magnetically Latched Lighting Contactors are designed to withstand the large initial inrush currents of tungsten lamp loads without contact welding.
- The A202 Contactors are fully rated devices that do not require de-rating similar to standard motor control contactors.

- The Magnetically Latched Lighting Contactor provides effective control in applications such as office buildings, industrial plants, hospitals, stadiums, airports, etc.

Features

- Designed and tested specifically for lighting and resistive loads
- Easy to install and maintain
- No control power necessary to maintain contact closure

Operation

A permanent magnet is built into the contactor structure that will maintain the contactor in its energized state indefinitely without using control power. When energized, a DC current is applied to the latch coil, producing a magnetic field that reinforces the polarity of the permanent magnet, pulling in the contactor. The coil clearing interlock disconnects the current to the coil. In order to drop out the contactor, it is necessary to apply a field through the STOP coil in the reverse direction to the permanent magnet. This momentarily cancels the magnetic attraction and the contactor drops out.

Instructional Leaflets

- IL16965 30A (2, 3, 4, 5 Poles)
- IL16966 60 – 200A (2, 3, 4, 5 Poles)

Standards and Certifications

- UL Listed File # E44424, Guide NRNT
- CSA Certified File # LR39402, Class 3231-01



Technical Data and Specifications

- Terminals
 - All except 30A devices: Cu/Al
 - 30A devices: Cu only
- Ballast load: 600 AC, breaking all lines
- Tungsten lamp loads, maximum volts
 - Line-to-line: 480V AC
 - Line-to-neutral: 277V AC

Accessories

See A200 NEMA Contactor Accessories, Page 33-166 – 33-168.

Wiring Diagrams

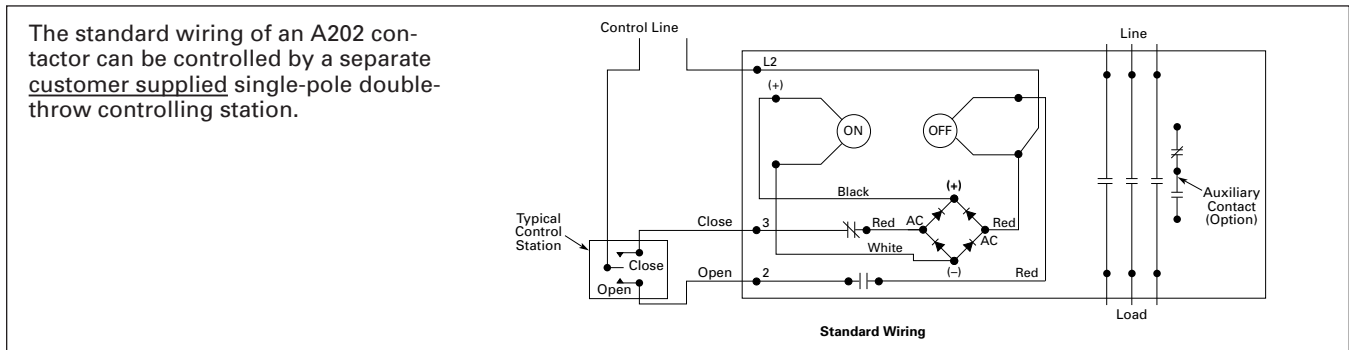

Figure 37-8. Standard Wiring

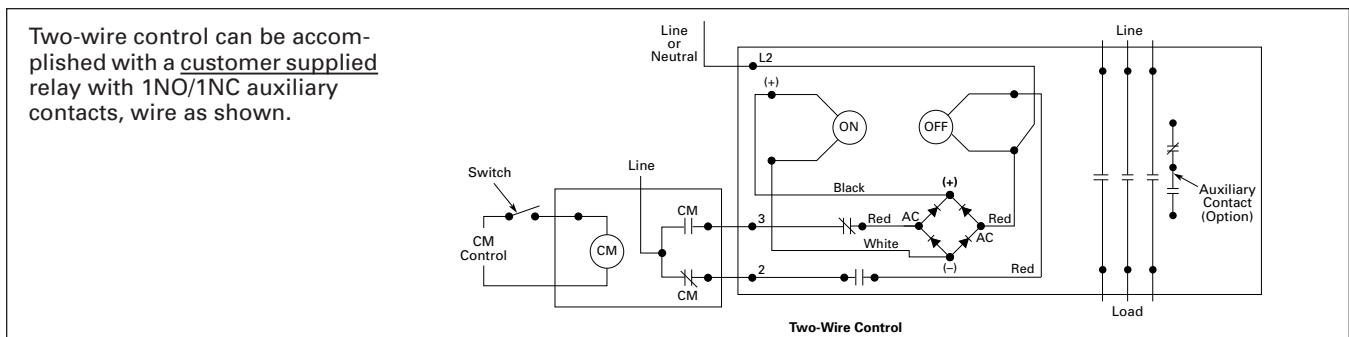

Figure 37-9. Two-Wire Control

A202 Magnetically Latched

Renewal Parts

Table 37-36. AC Coil Renewal Parts for A202 — Magnetically Latched

Voltage	Hz	2-, 3-, 4-Pole		5-Pole	
		Part Number	Price U.S. \$	Part Number	Price U.S. \$
30 Ampere					
110/120	50/60	7874A93G01		7874A89G01	
208/240		7874A93G02		7874A89G02	
277		7874A93G03		7874A89G03	
440/480		7874A93G04		7874A89G04	
575		7874A93G05		7874A89G05	
60 Ampere					
		2-, 3-Pole		4-, 5-Pole	
110/120	50/60	7874A93G01		7874A87G01	
208/240		7874A93G02		7874A87G02	
277		7874A93G03		7874A87G03	
440/480		7874A93G04		7874A87G04	
575		7874A93G05		7874A87G05	
100 and 200 Ampere					
110/120	50/60	7874A85G01		7874A83G01	
208/240		7874A85G02		7874A83G02	
277		7874A85G03		7874A83G03	
440/480		7874A85G04		7874A83G04	
550/575		7874A85G05		7874A83G05	

37

Table 37-37. Terminals (Line and Load)

2-Pole		3-Pole		4-Pole		5-Pole	
Part Number	Price U.S. \$	Part Number	Price U.S. \$	Part Number	Price	Part Number	Price U.S. \$
30 Ampere							
N/A		N/A		N/A		N/A	
60 Ampere							
179C755G17		179C755G16		179C755G17 ①		179C755G16 179C755G17 ②	
100 Ampere							
179C755G19		179C755G18		179C755G19 ①		179C755G18 179C755G19 ②	
200 Ampere Model K Electrically Held							
179C755G28		179C755G27		179C755G28 ①		179C755G27 179C755G28 ②	
200 Ampere Model J Magnetically Latched							
179C755G31		179C755G30		179C755G31 ①		179C755G30 179C755G31 ②	

① Order quantity of two for 4-pole design.

② Group members for the 5-pole terminal represent the combination of the 2- and 3-pole number.

Table 37-38. Other Accessories

Description	Size	Part Number	Price U.S. \$
Control Module (Rectifier)	30 – 200A	3915B98G01	

Arc boxes, upper base assemblies and cross bars are equivalent to the A201 series. See **Page 33-166**.

Contact kits are equivalent to the A201 Model J series, with the exception of the magnetically latched 200 ampere unit. It uses Catalog Number 672B788G07 for the 3-pole device. For other poles, consult factory.

A202 Magnetically Latched

Dimensions

Table 37-39. Approximate Dimensions for Non-combination Open Lighting Contactors — 2- to 12-Pole

Continuous Amperes	Number of Poles	Pole Configuration	Dimensions in Inches (mm)	
			Open Type	
			Wide A	High B
30	2-4	3 x 3 4 x 4 5 x 5 4 x 4 x 4	3.31 (84.1)	4.38 (111.3)
	5		4.19 (106.4)	4.38 (111.3)
	6		7.13 (181.1)	4.46 (113.3)
	8		7.13 (181.1)	4.46 (113.3)
	10		10.63 (270.0)	4.46 (113.3)
60	2,3	3 x 3 4 x 4 5 x 5 5 x 5 x 2	3.31 (84.1)	4.38 (111.3)
	4,5		4.19 (106.4)	4.38 (111.3)
	6		7.13 (181.1)	4.46 (113.3)
	8		10.63 (270.0)	4.46 (113.3)
	10		10.63 (270.0)	4.46 (113.3)
100	2,3	3 x 3 5 x 3 5 x 5 5 x 5 x 2	4.63 (117.6)	6.63 (168.4)
	4,5		7.25 (184.2)	6.63 (168.4)
	6		9.75 (247.7)	6.88 (174.8)
	8		12.38 (314.5)	6.88 (174.8)
	10		15.00 (381.0)	6.88 (174.8)
200	2,3	3 x 3 5 x 3 5 x 5 5 x 5 x 2	4.63 (117.6)	6.63 (168.4)
	4,5		7.25 (184.2)	6.63 (168.4)
	6		9.75 (247.7)	6.88 (174.8)
	8		12.38 (314.5)	6.88 (174.8)
	10		15.00 (381.0)	6.88 (174.8)
400	2,3	3 x 3 5 x 3 5 x 5 5 x 5 x 2	4.63 (117.6)	6.63 (168.4)
	4,5		7.25 (184.2)	6.63 (168.4)
	6		9.75 (247.7)	6.88 (174.8)
	8		12.38 (314.5)	6.88 (174.8)
	10		15.00 (381.0)	6.88 (174.8)

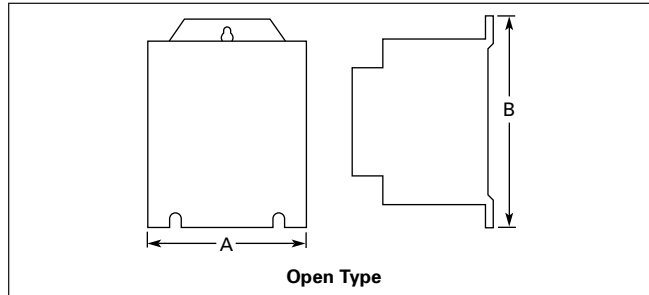

Figure 37-10. Approximate Dimensions

Product Selection

When Ordering Specify

- Catalog Number with Coil Suffix Code from the Magnet Coil Selection Table.
- Any required Accessories.

Table 37-40. Latched AC Lighting Contactors ①②

Holding Circuit Auxiliary Contact or Pushbutton Station Not Included				
Continuous Amperes (Enclosed)	Number of Poles	Open Type		
		Catalog Number ③	Price U.S. \$	
30	2	A202K1B_M		
	3	A202K1C_M		
	4	A202K1D_M		
	5	A202K1E_M		
	6	A202K1F_M		
	8	A202K1G_M		
	10	A202K1H_M		
	12	A202K1K_M		
	60	2	A202K2B_M	
		3	A202K2C_M	
		4	A202K2D_M	
		5	A202K2E_M	
6		A202K2F_M		
8		A202K2G_M		
10		A202K2H_M		
12		A202K2K_M		
100		2	A202K3B_M	
		3	A202K3C_M	
		4	A202K3D_M	
		5	A202K3E_M	
	6	A202K3F_M		
	8	A202K3G_M		
	10	A202K3H_M		
	12	A202K3K_M		
	200	2	A202K4B_M	
		3	A202K4C_M	
		4	A202K4D_M	
		5	A202K4E_M	
6		A202K4F_M		
8		A202K4G_M		
10		A202K4H_M		
12		A202K4K_M		
300		2	A202K5B_M	
		3	A202K5C_M	
400		2	A202K6B_M	
		3	A202K6C_M	

- ① Lighting contactors are not available with DC coils.
- ② Contactors rated 300A and 400A are mechanically latched.
- ③ Underscore (_) indicates missing Code letter for Magnet Coil Selection — see Magnet Coil Selection Table.

Table 37-41. Magnet Coil Selection

Coil Voltage	Catalog Number Suffix
120V, 60 Hz	A
208V, 60 Hz	B
277V, 60 Hz	Z
440V/50, 480V/60	X
600V, 60 Hz	E
120V/60, 110V/50	A
220V/50, 240V/60	W
24V, 60 Hz	I ④

- ④ Available on 2- to 5-pole, 30 and 60A devices and on 2- to 3-pole 100 and 200A devices.

Product Family Overview

Contents

<i>Description</i>	<i>Page</i>
Product Family Overview	37-20
Cover Control	37-22
Catalog Number Selection	37-21
C30CN Electrically and Mechanically Held	37-23
CN35 Electrically Held	37-24
A202 Magnetically Latched	37-26
Combination	37-28
Wiring Diagrams	37-29

Product Description

Eaton's Cutler-Hammer® Lighting Contactors are designed to provide a safe, convenient means for local or remote switching of tungsten (incandescent filament) or ballast (fluorescent and mercury arc) lamp loads. They are also suitable for other loads such as low pressure and high pressure sodium lamp loads and other non-motor (resistive) loads. They are not recommended for most sign flashing loads.

These lighting contactors are designed to withstand the large initial inrush currents of tungsten lamp loads without contact welding. They are fully rated and do not require derating.

Application Description

Loads:

Ballast Lamps — Fluorescent, Mercury Vapor, Metal Halide Sodium Vapor, Quartz — 600V maximum.

Filament Lamps — Incandescent, Infrared, Heating — 480V maximum, line to line; 277V maximum line to neutral.

Resistance Heating — Radiant and convection heating, furnaces and ovens.

Standards and Certifications

Note: See **P03300001E** for additional information on Standards and Certifications that apply to all Cutler-Hammer Enclosed Control products.

- UL Listed
- cUL Listed
- ABS Type Approved

Accessories

Auxiliary Contacts

C30CN Electrically Held Contactors — The base C30CN product line can accept up to four auxiliary contacts (2NO/2NC), which are mounted on the top of the unit. The auxiliary contacts, rated A600, are also suitable for use on low-level circuits down to 12V, 5 mA.

CN35 Electrically Held Contactors — Include a NO maintaining auxiliary contact mounted on the right side of the contactor. The 10 – 60A devices will accept additional auxiliary contacts on the top (front) and/or sides. The 100 – 400A sizes will accept side mounted auxiliaries only.

Mechanically Held and Magnetically Latched — Holding circuit auxiliary contact, if needed, is not included and should be added separately as an option.

Power Poles for C30CN

The C30CN can be configured with up to 12 poles (30A maximum per pole). Power poles are available in single or double pole designs and can be mounted to provide either normally open or normally closed operation with a maximum of 12 NO poles or 8 NC and 4 NO poles. Each pole is capable of accepting up to 8 AWG wire.

2-Wire or 3-Wire Control Module for C30CN

A mechanical latch with a 2- or 3-wire electronic control module delivers reliable performance and protection from such application abnormalities as line noise, leakage currents from controller outputs, or short repetitive commands burst from faulty controllers. For Enclosed Control, units come standard with 2-wire control.

IMPORTANT: Add the **C18** Modification code to get 3-wire control with the C30CN contactor.

Mechanically Held Kit for C30CN

A modification kit allows the conversion of an electrically held lighting contactor into a mechanically held contactor.

Coil Kits for C30CN

The C30CN line comes in a wide range of input voltages and with coils from 24V AC to 600V AC.

2-Wire Control Relay for A202

The 2-wire control relay is designed to field convert 3-wire magnetically latched lighting contactors to operate controls such as photocells and timers. Terminal blocks included for fast wiring installation.



Enclosed Lighting Contactors

Table 37-42. Type 1 2-Wire Control Relay

Description	Magnetic Coil Voltage	Type 1		Type 3R	
		Catalog Number	Price U.S. \$	Catalog Number	Price U.S. \$
2-Wire Control Relay	120	ECLC201A		ECLC202A	
	208	ECLC201E		ECLC202E	
	240	ECLC201B		ECLC202B	
	277	ECLC201H		ECLC202H	
	480	ECLC201C		ECLC202C	

Discount Symbol **1CD-1C**

Catalog Number Selection

Table 37-43. Enclosed Lighting Contactor Catalog Numbering System

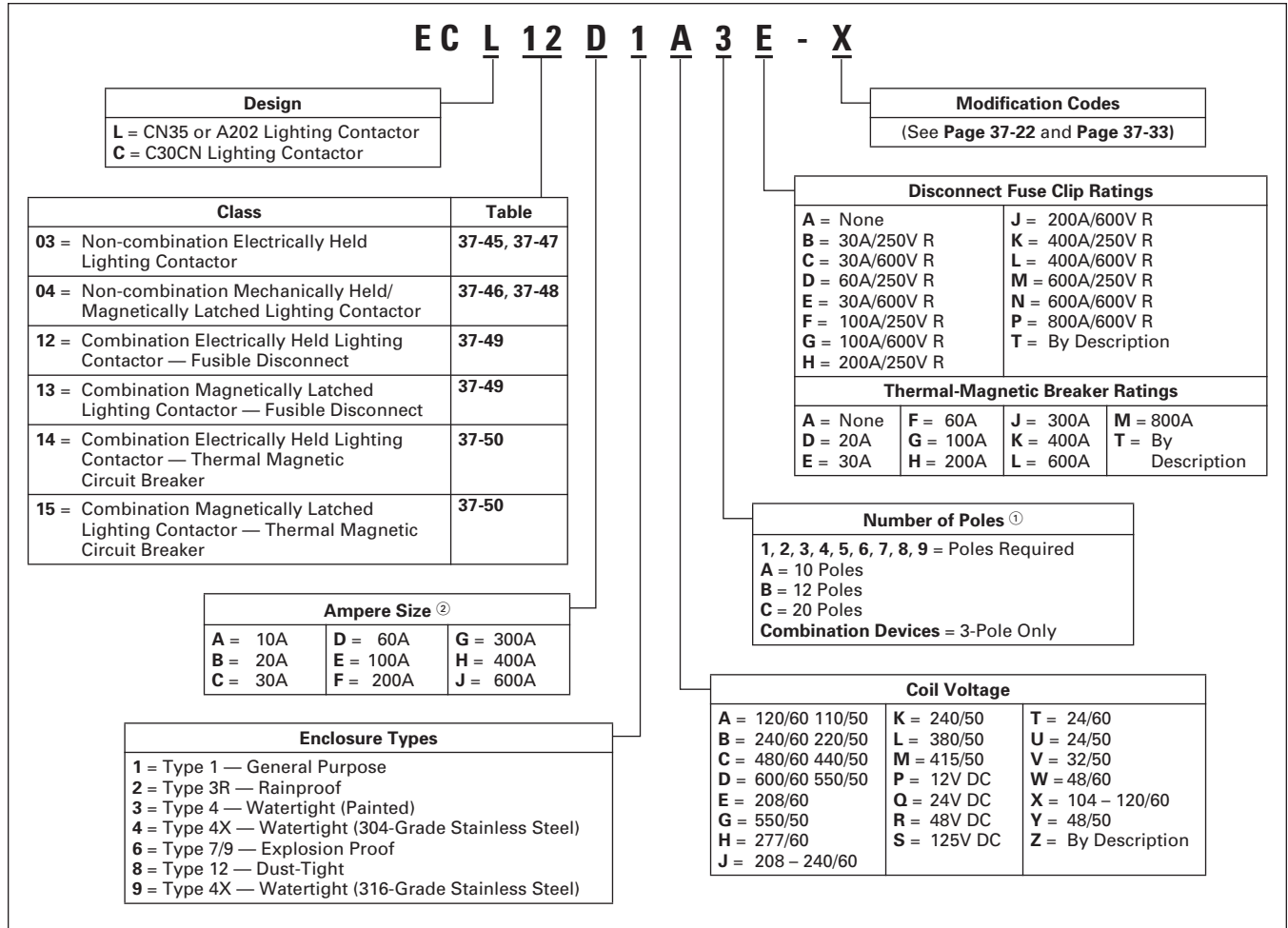

① For normally closed poles see Page 37-36.

② C30CN available in 30A only.

Enclosures

Lighting contactors are available open or mounted in Type 1, 3R, 4, 4X, 12 or 7/9 enclosures.

Type 1 is for indoor, general purpose for personal protection. Knock-outs are provided in the top and bottom for conduit entry.

Type 3R is for outdoor applications and rated for rain, sleet and external ice buildup. Type 3R enclosures have knockouts in the bottom and provisions for a hub in the top.

Type 4 and 4X are for mounting indoor or outdoor and provide protection from splashing water, hose-directed water and wind-blown dust. Watertight conduit hubs are provided in the top and bottom of Type 4X enclosures. The standard Type 4X enclosures are made of 304-Grade stainless steel, providing corrosion protection. 316-Grade stainless steel construction is available as an upgrade option.

Type 12 enclosures are for indoor mounting and protect from dripping liquids, falling dirt and dust. No knock-outs or hubs are provided with Type 12 enclosures.

Type 1, 3R, 4 and 12 enclosures are painted with a polyester urethane powder coat paint meeting UL requirements and the color is ANSI 61 gray. Type 1 enclosures have knockouts for cover controls. All the other Types have holes plugged, ready for cover controls. Type 7/9 is also available for explosion proof applications. Please contact the factory for additional details.

Product Family Overview

Cover Control

Table 37-44. Cover Mounted Pilot Devices

Description	For use with Lighting Contactor	Factory Installed Cover Control		Field Installation Kits			
		Type 1, 3R, 4X & 12	Type 7/9	Type 1 ①⑤		Type 3R, 4X, 12 Combination & Non-combination ②⑤	
		Modification Code Suffix	Modification Code Suffix	Catalog Number	Price U.S. \$	Catalog Number	Price U.S. \$
ON/OFF Pushbuttons with Red RUN Pilot Light with Red RUN/GREEN off lights	Electrical 3-wire C30CN; CN35; A202	P8 P8P23 P8P23P25	P8 P8P23 P8P23P25	C400GK18 C400GK19_ C400GK1A_		C400T2 — —	
ON/OFF Pushbuttons with Red RUN Pilot Light with Red RUN/GREEN off lights	Mechanical 3-wire C30CN	P8 P8P23 P8P23P25	P8 P8P23 P8P23P25	C400GK4 C400GK48_ C400GK49_		C400T201 — —	
ON/OFF Pushbuttons with Red RUN Pilot Light with Red RUN/GREEN off lights	Elec. & Mech. 2-wire C30CN; CN35; A202	P8 P8P23 P8P23P25	P8 P8P23 P8P23P25	C400GK5 C400GK52_ C400GK55_		C400T14 ③ — —	
Start/Stop Pushbuttons with Red RUN Pilot Light with Red RUN/GREEN off lights	Mechanical 3-wire C30CN	P7 P7P23 P7P23P25	P7 P7P23 P7P23P25	C400GK7 C400GK72_ C400GK75_		C400T200 — —	
Start/Stop Pushbuttons with Red RUN Pilot Light with Red RUN/GREEN off lights	Elec. & Mech. 2-wire C30CN	P7 P7P23 P7P23P25	P7 P7P23 P7P23P25	C400GK6 C400GK62_ C400GK65_		C400T13 ③ — —	
HAND/OFF/AUTO Cover Control with Red RUN Pilot Light with Red RUN/GREEN off lights	Elec. & Mech. 2-wire C30CN; N35; A202	S3 S3P23 S3P23P25	S3 ④ S3P23 ④ S3P23P25 ④	C400GK3 C400GK32_ C400GK35_		C400T12 ③ — —	
Red RUN Pilot Light Green OFF Pilot Light Red RUN/Green OFF Pilot Light	All	P23 P25 P23P25	P23 P25 P23P25	C400GK42_ C400GK41_ C400GK46_		C400T9_ C400T10_ C400T11_	

- ① For use with Non-combination units (Box sizes 1 – 4).
- ② For use with Type 1 Combination units as well.
- ③ Selector Switch.
- ④ With 3-position selector switch, Mod C20 (2-wire control relay) must be used with magnetically latched contactor (ECL04, ECL13, ECL15).

⑤ Add Code Letter from table below to Catalog Number for Voltage in place of _.

Rating	Code Letter	Rating	Code Letter
24V 60 Hz	T	277V 60 Hz	H
120V 60 Hz	A	380V 60 Hz	L
208V 60 Hz	E	480V 60 Hz	C
240V 60 Hz	B	600V 60 Hz	D

Discount Symbol 1CD-1C

Product Selection

2-Wire and 3-Wire Control Wiring Options — 2-Wire Control Standard



*Enclosed Electrically Held
Lighting Contactor*



*Enclosed Mechanically Held
Lighting Contactor*

Table 37-45. Class ECC03 — Non-combination Electrically Held Lighting Contactor — 2 or 3-Wire Control

Number of Poles	Type 1		Type 3R		Type 4X ①		Type 7/9		Type 12		Component Contactor (Open)
	Catalog Number ②	Price U.S. \$	Catalog Number ②	Price U.S. \$	Catalog Number ②	Price U.S. \$	Catalog Number ②	Price U.S. \$	Catalog Number ②	Price U.S. \$	Catalog Number ②
Continuous Amps – 30											
2	ECC03C1_2A		ECC03C2_2A		ECC03C4_2A		ECC03C6_2A		ECC03C8_2A		C30CNE20_0
3	ECC03C1_3A		ECC03C2_3A		ECC03C4_3A		ECC03C6_3A		ECC03C8_3A		C30CNE30_0
4	ECC03C1_4A		ECC03C2_4A		ECC03C4_4A		ECC03C6_4A		ECC03C8_4A		C30CNE40_0
5	ECC03C1_5A		ECC03C2_5A		ECC03C4_5A		ECC03C6_5A		ECC03C8_5A		C30CNE50_0
6	ECC03C1_6A		ECC03C2_6A		ECC03C4_6A		ECC03C6_6A		ECC03C8_6A		C30CNE60_0
7	ECC03C1_7A		ECC03C2_7A		ECC03C4_7A		ECC03C6_7A		ECC03C8_7A		C30CNE70_0
8	ECC03C1_8A		ECC03C2_8A		ECC03C4_8A		ECC03C6_8A		ECC03C8_8A		C30CNE80_0
9	ECC03C1_9A		ECC03C2_9A		ECC03C4_9A		ECC03C6_9A		ECC03C8_9A		C30CNE90_0
10	ECC03C1_AA		ECC03C2_AA		ECC03C4_AA		ECC03C6_AA		ECC03C8_AA		C30CNE100_0
12	ECC03C1_BA		ECC03C2_BA		ECC03C4_BA		ECC03C6_BA		ECC03C8_BA		C30CNE120_0

① These are the Catalog Numbers for Type 4X 304-Grade Stainless Steel, as indicated by the seventh digit 4. Example: ECC03C4A2A. To order Type 4X 316-Grade Stainless Steel, change that digit to 9. To order Type 4 Painted Steel, change that digit to 3. To order Nonmetallic, change that digit to 5. For details on these Alternate Enclosures, see **PG03300001E**.

② For first open position (Coil Voltage), use the table below.

Suffix	Coil Voltage	Suffix	Coil Voltage	Suffix	Coil Voltage
A	120/60 or 110/50	D	600/60 or 550/50	T	24/60
B	240/60 or 220/50	E	208/60	V	28/60 or 24/50
C	480/60 or 440/50	H	277/60 or 240/50	X	347/60

Table 37-46. Class ECC04 — Non-combination Mechanically Held Lighting Contactor — 2-Wire Control ③

Number of Poles	Type 1		Type 3R		Type 4X ④		Type 7/9		Type 12		Component Contactor (Open)
	Catalog Number ⑤	Price U.S. \$	Catalog Number ⑤	Price U.S. \$	Catalog Number ⑤	Price U.S. \$	Catalog Number ⑤	Price U.S. \$	Catalog Number ⑤	Price U.S. \$	Catalog Number ⑤
Continuous Amps – 30											
2	ECC04C1_2A		ECC04C2_2A		ECC04C4_2A		ECC04C6_2A		ECC04C8_2A		C30CNM20_0
3	ECC04C1_3A		ECC04C2_3A		ECC04C4_3A		ECC04C6_3A		ECC04C8_3A		C30CNM30_0
4	ECC04C1_4A		ECC04C2_4A		ECC04C4_4A		ECC04C6_4A		ECC04C8_4A		C30CNM40_0
5	ECC04C1_5A		ECC04C2_5A		ECC04C4_5A		ECC04C6_5A		ECC04C8_5A		C30CNM50_0
6	ECC04C1_6A		ECC04C2_6A		ECC04C4_6A		ECC04C6_6A		ECC04C8_6A		C30CNM60_0
7	ECC04C1_7A		ECC04C2_7A		ECC04C4_7A		ECC04C6_7A		ECC04C8_7A		C30CNM70_0
8	ECC04C1_8A		ECC04C2_8A		ECC04C4_8A		ECC04C6_8A		ECC04C8_8A		C30CNM80_0
9	ECC04C1_9A		ECC04C2_9A		ECC04C4_9A		ECC04C6_9A		ECC04C8_9A		C30CNM90_0
10	ECC04C1_AA		ECC04C2_AA		ECC04C4_AA		ECC04C6_AA		ECC04C8_AA		C30CNM100_0
12	ECC04C1_BA		ECC04C2_BA		ECC04C4_BA		ECC04C6_BA		ECC04C8_BA		C30CNM120_0

③ Add **C18** Modification Code for 3-wire control.

④ These are the Catalog Numbers for Type 4X 304-Grade Stainless Steel, as indicated by the seventh digit 4. Example: ECC04C4A2A. To order Type 4X 316-Grade Stainless Steel, change that digit to 9. To order Type 4 Painted Steel, change that digit to 3. To order Nonmetallic, change that digit to 5. For details on these Alternate Enclosures, see **PG03300001E**.

⑤ For first open position (Coil Voltage), use the table below.

Suffix	Coil Voltage	Suffix	Coil Voltage	Suffix	Coil Voltage
A	120/60 or 110/50	D	600/60 or 550/50	T	24/60
B	240/60 or 220/50	E	208/60	V	28/60 or 24/50
C	480/60 or 440/50	H	277/60 or 240/50	X	347/60

Note: To get the C30CN Lighting Contactor with normally closed power poles, see **Page 37-36**, section L, for Modification Codes.

Cover Control **Page 37-22**
 Dimensions **PG03300001E**
 Accessories **PG03300001E**
 Modifications **Page 37-33**
 Discount Symbol **1CD-1C**

Non-combination CN35 Electrically Held

Product Selection

Table 37-47. Class ECL03 — Non-combination Electrically Held Lighting Contactor

No. of Poles	Frame Size	Type 1 General Purpose		Type 3R Rainproof		Type 4X ^② Watertight & Dust-Tight Stainless Steel		Type 7/9 Hazardous Location		Type 12 Dust-Tight Industrial		Component Contactor (Open)	
		Catalog Number ^③	Price U.S. \$	Catalog Number ^③	Price U.S. \$	Catalog Number ^③	Price U.S. \$	Catalog Number ^③	Price U.S. \$	Catalog Number ^③	Price U.S. \$	Catalog Number ^③	
Maximum Ampere Rating — 10^①													
2	45 mm	ECL03A1_2A		ECL03A2_2A		ECL03A4_2A		ECL03A6_2A		ECL03A8_2A		CN35AN2_B	
3		ECL03A1_3A		ECL03A2_3A		ECL03A4_3A		ECL03A6_3A		ECL03A8_3A		CN35AN3_B	
4		ECL03A1_4A		ECL03A2_4A		ECL03A4_4A		ECL03A6_4A		ECL03A8_4A		CN35AN4_B	
5		ECL03A1_5A		ECL03A2_5A		ECL03A4_5A		ECL03A6_5A		ECL03A8_5A		—	
6		ECL03A1_6A		ECL03A2_6A		ECL03A4_6A		ECL03A6_6A		ECL03A8_6A		—	
9		45 mm	ECL03A1_9A		ECL03A2_9A		ECL03A4_9A		ECL03A6_9A		ECL03A8_9A		—
10	ECL03A1_AA			ECL03A2_AA		ECL03A4_AA		ECL03A6_AA		ECL03A8_AA		—	
12	ECL03A1_BA			ECL03A2_BA		ECL03A4_BA		ECL03A6_BA		ECL03A8_BA		—	
20	ECL03A1_CA			ECL03A2_CA		ECL03A4_CA		ECL03A6_CA		ECL03A8_CA		—	
Maximum Ampere Rating — 20^①													
2	45 mm	ECL03B1_2A		ECL03B2_2A		ECL03B4_2A		ECL03B6_2A		ECL03B8_2A		CN35BN2_B	
3		ECL03B1_3A		ECL03B2_3A		ECL03B4_3A		ECL03B6_3A		ECL03B8_3A		CN35BN3_B	
4		ECL03B1_4A		ECL03B2_4A		ECL03B4_4A		ECL03B6_4A		ECL03B8_4A		CN35BN4_B	
5		ECL03B1_5A		ECL03B2_5A		ECL03B4_5A		ECL03B6_5A		ECL03B8_5A		—	
6		ECL03B1_6A		ECL03B2_6A		ECL03B4_6A		ECL03B6_6A		ECL03B8_6A		CN35BN6_B	
9		45 mm	ECL03B1_9A		ECL03B2_9A		ECL03B4_9A		ECL03B6_9A		ECL03B8_9A		CN35BN9_B
10	ECL03B1_AA			ECL03B2_AA		ECL03B4_AA		ECL03B6_AA		ECL03B8_AA		—	
12	ECL03B1_BA			ECL03B2_BA		ECL03B4_BA		ECL03B6_BA		ECL03B8_BA		CN35BN12_B	
20	ECL03B1_CA			ECL03B2_CA		ECL03B4_CA		ECL03B6_CA		ECL03B8_CA		—	
Maximum Ampere Rating — 30^①													
2	45 mm	ECL03C1_2A		ECL03C2_2A		ECL03C4_2A		ECL03C6_2A		ECL03C8_2A		CN35DN2_B	
3		ECL03C1_3A		ECL03C2_3A		ECL03C4_3A		ECL03C6_3A		ECL03C8_3A		CN35DN3_B	
4		ECL03C1_4A		ECL03C2_4A		ECL03C4_4A		ECL03C6_4A		ECL03C8_4A		CN35DN4_B	
5		ECL03C1_5A		ECL03C2_5A		ECL03C4_5A		ECL03C6_5A		ECL03C8_5A		CN35DN5_B	
6		ECL03C1_6A		ECL03C2_6A		ECL03C4_6A		ECL03C6_6A		ECL03C8_6A		CN35DN6_B	
9		45 mm	ECL03C1_9A		ECL03C2_9A		ECL03C4_9A		ECL03C6_9A		ECL03C8_9A		CN35DN9_B
10	ECL03C1_AA			ECL03C2_AA		ECL03C4_AA		ECL03C6_AA		ECL03C8_AA		—	
12	ECL03C1_BA			ECL03C2_BA		ECL03C4_BA		ECL03C6_BA		ECL03C8_BA		CN35DN12_B	
20	ECL03C1_CA			ECL03C2_CA		ECL03C4_CA		ECL03C6_CA		ECL03C8_CA		—	
Maximum Ampere Rating — 60^①													
2	65 mm	ECL03D1_2A		ECL03D2_2A		ECL03D4_2A		ECL03D6_2A		ECL03D8_2A		CN35GN2_B	
3		ECL03D1_3A		ECL03D2_3A		ECL03D4_3A		ECL03D6_3A		ECL03D8_3A		CN35GN3_B	
4		ECL03D1_4A		ECL03D2_4A		ECL03D4_4A		ECL03D6_4A		ECL03D8_4A		CN35GN4_B	
5		ECL03D1_5A		ECL03D2_5A		ECL03D4_5A		ECL03D6_5A		ECL03D8_5A		CN35GN5_B	
6		65 mm	ECL03D1_6A		ECL03D2_6A		ECL03D4_6A		ECL03D6_6A		ECL03D8_6A		—
9			ECL03D1_9A		ECL03D2_9A		ECL03D4_9A		ECL03D6_9A		ECL03D8_9A		—
10	ECL03D1_AA			ECL03D2_AA		ECL03D4_AA		ECL03D6_AA		ECL03D8_AA		—	
12	ECL03D1_BA		ECL03D2_BA		ECL03D4_BA		ECL03D6_BA		ECL03D8_BA		—		

① Ampere ratings are based on a maximum load voltage of 480V for tungsten lamp applications and 600V for ballast or mercury vapor type applications.

② These are the Catalog Numbers for Type 4X 304-Grade Stainless Steel, as indicated by the seventh digit 4. Example: ECL03B4A2A. To order Type 4X 316-Grade Stainless Steel, change that digit to 9. To order Type 4 Painted Steel, change that digit to 3. To order Nonmetallic, change that digit to 5. For details on these Alternate Enclosures, see PG03300001E.

③ For open position (Coil Voltage), use the table below:

Suffix	Coil Voltage
A	120/60 or 110/50
B	240/60 or 220/50
C	480/60 or 440/50
D	600/60 or 550/50
E	208/60
H	277/60



Type 1 Electrically Held
4-Pole Lighting Contactor

Cover Control Page 37-22
 Dimensions PG03300001E
 Accessories PG03300001E
 Modifications Page 37-33
 Discount Symbol 1CD-1C

Non-combination CN35 Electrically Held

Table 37-47. Class ECL03 — Non-combination Electrically Held Lighting Contactor (Continued)

No. of Poles	Frame Size	Type 1 General Purpose		Type 3R Rainproof		Type 4X ^③ Watertight & Dust-Tight Stainless Steel		Type 7/9 Hazardous Location		Type 12 Dust-Tight Industrial		Component Contactor (Open) Catalog Number ④
		Catalog Number ④	Price U.S. \$	Catalog Number ④	Price U.S. \$	Catalog Number ④	Price U.S. \$	Catalog Number ④	Price U.S. \$	Catalog Number ④	Price U.S. \$	
Maximum Ampere Rating — 100^①												
2 3 4	90 mm	ECL03E1_2A ECL03E1_3A ECL03E1_4A		ECL03E2_2A ECL03E2_3A ECL03E2_4A		ECL03E4_2A ECL03E4_3A ECL03E4_4A		ECL03E6_2A ECL03E6_3A ECL03E6_4A		ECL03E8_2A ECL03E8_3A ECL03E8_4A		CN35KN2_ CN35KN3_ —
5 6 9	90 mm	ECL03E1_5A ECL03E1_6A ECL03E1_9A		ECL03E2_5A ECL03E2_6A ECL03E2_9A		ECL03E4_5A ECL03E4_6A ECL03E4_9A		ECL03E6_5A ECL03E6_6A ECL03E6_9A		ECL03E8_5A ECL03E8_6A ECL03E8_9A		— — —
Maximum Ampere Rating — 200^①												
2 3 4	180 mm	ECL03F1_2A ECL03F1_3A ECL03F1_4A		ECL03F2_2A ECL03F2_3A ECL03F2_4A		ECL03F4_2A ECL03F4_3A ECL03F4_4A		ECL03F6_2A ECL03F6_3A ECL03F6_4A		ECL03F8_2A ECL03F8_3A ECL03F8_4A		CN35NN2_ CN35NN3_ —
5 6	180 mm	ECL03F1_5A ECL03F1_6A		ECL03F2_5A ECL03F2_6A		ECL03F4_5A ECL03F4_6A		ECL03F6_5A ECL03F6_6A		ECL03F8_5A ECL03F8_6A		— —
Maximum Ampere Rating — 300^①												
2 3 4	180 mm	ECL03G1_2A ECL03G1_3A ECL03G1_4A		ECL03G2_2A ECL03G2_3A ECL03G2_4A		ECL03G4_2A ECL03G4_3A ECL03G4_4A		ECL03G6_2A ECL03G6_3A ECL03G6_4A		ECL03G8_2A ECL03G8_3A ECL03G8_4A		CN35SN2_ CN35SN3_ —
5 6	180 mm	ECL03G1_5A ECL03G1_6A		ECL03G2_5A ECL03G2_6A		ECL03G4_5A ECL03G4_6A		ECL03G6_5A ECL03G6_6A		ECL03G8_5A ECL03G8_6A		— —
Maximum Ampere Rating — 400^{①②}												
2 3	220 mm	ECL03H1_2A ECL03H1_3A		ECL03H2_2A ECL03H2_3A		ECL03H4_2A ECL03H4_3A		ECL03H6_2A ECL03H6_3A		ECL03H8_2A ECL03H8_3A		CN35TN2_ CN35TN3_

① Ampere ratings are based on a maximum load voltage of 480V for tungsten lamp applications and 600V for ballast or mercury vapor type applications.
② UL ballast and resistive ratings only.

③ These are the Catalog Numbers for Type 4X 304-Grade Stainless Steel, as indicated by the seventh digit 4. Example: ECL03B4A2A. To order Type 4X 316-Grade Stainless Steel, change that digit to 9. To order Type 4 Painted Steel, change that digit to 3. To order Nonmetallic, change that digit to 5. For details on these Alternate Enclosures, see PG03300001E.

④ For open position (Coil Voltage), use the table below:

Suffix	Coil Voltage
A	120/60 or 110/50
B	240/60 or 220/50
C	480/60 or 440/50
D	600/60 or 550/50
E	208/60
H	277/60

Cover Control Page 37-22
 Dimensions PG03300001E
 Accessories PG03300001E
 Modifications Page 37-33
 Discount Symbol 1CD-1C

Non-combination A202 Magnetically Latched

Operation

A permanent magnet is built into the contactor structure that will maintain the contactor in its energized state indefinitely without using control power. When energized, a DC current is applied to the latch coil, producing a

magnetic field that reinforces the polarity of the permanent magnet, pulling in the contactor. The current to the coil is disconnected by the coil clearing interlock. In order to drop out the contactor, it is necessary to apply a field through

the STOP coil in the reverse direction to the permanent magnet. This momentarily cancels the magnetic attraction and the contactor drops out.

Product Selection

Table 37-48. Class ECL04 — Non-combination Magnetically Latched Lighting Contactor

No. of Poles	Type 1 General Purpose		Type 3R Rainproof		Type 4X ② Watertight & Dust-Tight Stainless Steel		Type 7/9 Hazardous Location		Type 12 Dust-Tight Industrial		Component Contactor (Open)
	Catalog Number ③	Price U.S. \$	Catalog Number ③	Price U.S. \$	Catalog Number ③	Price U.S. \$	Catalog Number ③	Price U.S. \$	Catalog Number ③	Price U.S. \$	Catalog Number ③
Maximum Ampere Rating — 30 ①											
2	ECL04C1_2A		ECL04C2_2A		ECL04C4_2A		ECL04C6_2A		ECL04C8_2A		A202K1B_M
3	ECL04C1_3A		ECL04C2_3A		ECL04C4_3A		ECL04C6_3A		ECL04C8_3A		A202K1C_M
4	ECL04C1_4A		ECL04C2_4A		ECL04C4_4A		ECL04C6_4A		ECL04C8_4A		A202K1D_M
5	ECL04C1_5A		ECL04C2_5A		ECL04C4_5A		ECL04C6_5A		ECL04C8_5A		A202K1E_M
6	ECL04C1_6A		ECL04C2_6A		ECL04C4_6A		ECL04C6_6A		ECL04C8_6A		A202K1F_M
8	ECL04C1_8A		ECL04C2_8A		ECL04C4_8A		ECL04C6_8A		ECL04C8_8A		A202K1G_M
9	ECL04C1_9A		ECL04C2_9A		ECL04C4_9A		ECL04C6_9A		ECL04C8_9A		—
10	ECL04C1_AA		ECL04C2_AA		ECL04C4_AA		ECL04C6_AA		ECL04C8_AA		A202K1H_M
12	ECL04C1_BA		ECL04C2_BA		ECL04C4_BA		ECL04C6_BA		ECL04C8_BA		A202K1K_M
20	ECL04C1_CA		ECL04C2_CA		ECL04C4_CA		ECL04C6_CA		ECL04C8_CA		—
Maximum Ampere Rating — 60 ①											
2	ECL04D1_2A		ECL04D2_2A		ECL04D4_2A		ECL04D6_2A		ECL04D8_2A		A202K2B_M
3	ECL04D1_3A		ECL04D2_3A		ECL04D4_3A		ECL04D6_3A		ECL04D8_3A		A202K2C_M
4	ECL04D1_4A		ECL04D2_4A		ECL04D4_4A		ECL04D6_4A		ECL04D8_4A		A202K2D_M
5	ECL04D1_5A		ECL04D2_5A		ECL04D4_5A		ECL04D6_5A		ECL04D8_5A		A202K2E_M
6	ECL04D1_6A		ECL04D2_6A		ECL04D4_6A		ECL04D6_6A		ECL04D8_6A		A202K2F_M
8	ECL04D1_8A		ECL04D2_8A		ECL04D4_8A		ECL04D6_8A		ECL04D8_8A		A202K2G_M
9	ECL04D1_9A		ECL04D2_9A		ECL04D4_9A		ECL04D6_9A		ECL04D8_9A		—
10	ECL04D1_AA		ECL04D2_AA		ECL04D4_AA		ECL04D6_AA		ECL04D8_AA		A202K2H_M
12	ECL04D1_BA		ECL04D2_BA		ECL04D4_BA		ECL04D6_BA		ECL04D8_BA		A202K2K_M
20	ECL04D1_CA		ECL04D2_CA		ECL04D4_CA		ECL04D6_CA		ECL04D8_CA		—
Maximum Ampere Rating — 100 ①											
2	ECL04E1_2A		ECL04E2_2A		ECL04E4_2A		ECL04E6_2A		ECL04E8_2A		A202K3B_M
3	ECL04E1_3A		ECL04E2_3A		ECL04E4_3A		ECL04E6_3A		ECL04E8_3A		A202K3C_M
4	ECL04E1_4A		ECL04E2_4A		ECL04E4_4A		ECL04E6_4A		ECL04E8_4A		A202K3D_M
5	ECL04E1_5A		ECL04E2_5A		ECL04E4_5A		ECL04E6_5A		ECL04E8_5A		A202K3E_M
6	ECL04E1_6A		ECL04E2_6A		ECL04E4_6A		ECL04E6_6A		ECL04E8_6A		A202K3F_M
8	ECL04E1_8A		ECL04E2_8A		ECL04E4_8A		ECL04E6_8A		ECL04E8_8A		A202K3G_M
9	ECL04E1_9A		ECL04E2_9A		ECL04E4_9A		ECL04E6_9A		ECL04E8_9A		—
10	ECL04E1_AA		ECL04E2_AA		ECL04E4_AA		ECL04E6_AA		ECL04E8_AA		A202K3H_M
12	ECL04E1_BA		ECL04E2_BA		ECL04E4_BA		ECL04E6_BA		ECL04E8_BA		A202K3K_M
20	ECL04E1_CA		ECL04E2_CA		ECL04E4_CA		ECL04E6_CA		ECL04E8_CA		—

① Ampere ratings are based on a maximum load voltage of 480V for tungsten lamp applications and 600V for ballast or mercury vapor type applications.

② These are the Catalog Numbers for Type 4X 304-Grade Stainless Steel, as indicated by the seventh digit 4. Example: ECL04C4A2A. To order Type 4X 316-Grade Stainless Steel, change that digit to 9. To order Type 4 Painted Steel, change that digit to 3. To order Nonmetallic, change that digit to 5. For details on these Alternate Enclosures, see PG03300001E.

③ For open position (Coil Voltage), use the table below:

Enclosed Suffix	Open Suffix	Coil Voltage
A	A	120/60 or 110/50
B	W	240/60 or 220/50
C	X	480/60 or 440/50
D	E	600/60
E	B	208/60
H	Z	277/60



Type 1 Non-combination Magnetically Latched Lighting Contactor

Accessories **Pages 37-20**
 Cover Control **Page 37-22**
 Dimensions **PG03300001E**
 Modifications **Page 37-33**
 Technical Data **PG03300001E**
 Discount Symbol **1CD-1C**

Non-combination A202 Magnetically Latched

Table 37-48. Class ECL04 — Non-combination Magnetically Latched Lighting Contactor (Continued)

No. of Poles	Type 1 General Purpose		Type 3R Rainproof		Type 4X ^② Watertight & Dust-Tight Stainless Steel		Type 7/9 Hazardous Location		Type 12 Dust-Tight Industrial		Component Contactor (Open)
	Catalog Number ^③	Price U.S. \$	Catalog Number ^③	Price U.S. \$	Catalog Number ^③	Price U.S. \$	Catalog Number ^③	Price U.S. \$	Catalog Number ^③	Price U.S. \$	Catalog Number ^③
Maximum Ampere Rating — 200^①											
2	ECL04F1_2A		ECL04F2_2A		ECL04F4_2A		ECL04F6_2A		ECL04F8_2A		A202K4B_M
3	ECL04F1_3A		ECL04F2_3A		ECL04F4_3A		ECL04F6_3A		ECL04F8_3A		A202K4C_M
4	ECL04F1_4A		ECL04F2_4A		ECL04F4_4A		ECL04F6_4A		ECL04F8_4A		A202K4D_M
5	ECL04F1_5A		ECL04F2_5A		ECL04F4_5A		ECL04F6_5A		ECL04F8_5A		A202K4E_M
6	ECL04F1_6A		ECL04F2_6A		ECL04F4_6A		ECL04F6_6A		ECL04F8_6A		A202K4F_M
8	ECL04F1_8A		ECL04F2_8A		ECL04F4_8A		ECL04F6_8A		ECL04F8_8A		A202K4G_M
9	ECL04F1_9A		ECL04F2_9A		ECL04F4_9A		ECL04F6_9A		ECL04F8_9A		—
10	ECL04F1_AA		ECL04F2_AA		ECL04F4_AA		ECL04F6_AA		ECL04F8_AA		A202K4H_M
12	ECL04F1_BA		ECL04F2_BA		ECL04F4_BA		ECL04F6_BA		ECL04F8_BA		A202K4K_M
20	ECL04F1_CA		ECL04F2_CA		ECL04F4_CA		ECL04F6_CA		ECL04F8_CA		—
Maximum Ampere Rating — 300^①											
2	ECL04G1_2A		ECL04G2_2A		ECL04G4_2A		ECL04G6_2A		ECL04G8_2A		A202K5B_M
3	ECL04G1_3A		ECL04G2_3A		ECL04G4_3A		ECL04G6_3A		ECL04G8_3A		A202K5C_M
4	ECL04G1_4A		ECL04G2_4A		ECL04G4_4A		ECL04G6_4A		ECL04G8_4A		—
5	ECL04G1_5A		ECL04G2_5A		ECL04G4_5A		ECL04G6_5A		ECL04G8_5A		—
6	ECL04G1_6A		ECL04G2_6A		ECL04G4_6A		ECL04G6_6A		ECL04G8_6A		—
Maximum Ampere Rating — 400^①											
2	ECL04H1_2A		ECL04H2_2A		ECL04H4_2A		ECL04H6_2A		ECL04H8_2A		A202K6B_M
3	ECL04H1_3A		ECL04H2_3A		ECL04H4_3A		ECL04H6_3A		ECL04H8_3A		A202K6C_M
4	ECL04H1_4A		ECL04H2_4A		ECL04H4_4A		ECL04H6_4A		ECL04H8_4A		—
5	ECL04H1_5A		ECL04H2_5A		ECL04H4_5A		ECL04H6_5A		ECL04H8_5A		—
6	ECL04H1_6A		ECL04H2_6A		ECL04H4_6A		ECL04H6_6A		ECL04H8_6A		—

① Ampere ratings are based on a maximum load voltage of 480V for tungsten lamp applications and 600V for ballast or mercury vapor type applications.

② These are the Catalog Numbers for Type 4X 304-Grade Stainless Steel, as indicated by the seventh digit 4. Example: ECL04C4A2A. To order Type 4X 316-Grade Stainless Steel, change that digit to 9. To order Type 4 Painted Steel, change that digit to 3. To order Nonmetallic, change that digit to 5. For details on these Alternate Enclosures, see PG03300001E.

③ For open position (Coil Voltage), use the table below:

Enclosed Suffix	Open Suffix	Coil Voltage
A	A	120/60 or 110/50
B	W	240/60 or 220/50
C	X	480/60 or 440/50
D	E	600/60
E	B	208/60
H	Z	277/60

Accessories Pages 37-20
 Cover Control Page 37-22
 Dimensions PG03300001E
 Modifications Page 37-33
 Technical Data PG03300001E
 Discount Symbol 1CD-1C

Combination Electrically Held and Magnetically Latched

Product Selection

Table 37-49. Class ECL12 & ECL13 — Combination Lighting Contactor — Fusible Disconnect

Max. Amp Rating ①	No. of Poles	Fuse Clips Amps/Volts ③	Type 1 General Purpose		Type 3R Rainproof		Type 4X Watertight & Dust-Tight SS		Type 7/9 Hazardous Location		Type 12 Dust-Tight Industrial		Component Contactor (Open)
			Catalog Number ②	Price U.S. \$	Catalog Number ②	Price U.S. \$	Catalog Number ②	Price U.S. \$	Catalog Number ②	Price U.S. \$	Catalog Number ②	Price U.S. \$	Catalog Number ②
Electrically Held — Class ECL12													
30	3	30/250V 30/600V	ECL12C1_3B ECL12C1_3C		ECL12C2_3B ECL12C2_3C		ECL12C4_3B ECL12C4_3C		ECL12C6_3B ECL12C6_3C		ECL12C8_3B ECL12C8_3C		CN35DN3_B
60	3	60/250V 60/600V	ECL12D1_3D ECL12D1_3E		ECL12D2_3D ECL12D2_3E		ECL12D4_3D ECL12D4_3E		ECL12D6_3D ECL12D6_3E		ECL12D8_3D ECL12D8_3E		CN35GN3_B
100	3	100/250V 100/600V	ECL12E1_3F ECL12E1_3G		ECL12E2_3F ECL12E2_3G		ECL12E4_3F ECL12E4_3G		ECL12E6_3F ECL12E6_3G		ECL12E8_3F ECL12E8_3G		CN35KN3_
200	3	200/250V 200/600V	ECL12F1_3H ECL12F1_3J		ECL12F2_3H ECL12F2_3J		ECL12F4_3H ECL12F4_3J		ECL12F6_3H ECL12F6_3J		ECL12F8_3H ECL12F8_3J		CN35NN3_
300	3	400/250V 400/600V	ECL12G1_3K ECL12G1_3L		ECL12G2_3K ECL12G2_3L		ECL12G4_3K ECL12G4_3L		ECL12G6_3K ECL12G6_3L		ECL12G8_3K ECL12G8_3L		CN35SN3_
400	3	400/250V 400/600V	ECL12H1_3K ECL12H1_3L		ECL12H2_3K ECL12H2_3L		ECL12H4_3K ECL12H4_3L		ECL12H6_3K ECL12H6_3L		ECL12H8_3K ECL12H8_3L		CN35TN3_
Magnetically Latched — Class ECL13													
30	3	30/250V 30/600V	ECL13C1_3B ECL13C1_3C		ECL13C2_3B ECL13C2_3C		ECL13C4_3B ECL13C4_3C		ECL13C6_3B ECL13C6_3C		ECL13C8_3B ECL13C8_3C		A202K1C_M
60	3	60/250V 60/600V	ECL13D1_3D ECL13D1_3E		ECL13D2_3D ECL13D2_3E		ECL13D4_3D ECL13D4_3E		ECL13D6_3D ECL13D6_3E		ECL13D8_3D ECL13D8_3E		A202K2C_M
100	3	100/250V 100/600V	ECL13E1_3F ECL13E1_3G		ECL13E2_3F ECL13E2_3G		ECL13E4_3F ECL13E4_3G		ECL13E6_3F ECL13E6_3G		ECL13E8_3F ECL13E8_3G		A202K3C_M
200	3	200/250V 200/600V	ECL13F1_3H ECL13F1_3J		ECL13F2_3H ECL13F2_3J		ECL13F4_3H ECL13F4_3J		ECL13F6_3H ECL13F6_3J		ECL13F8_3H ECL13F8_3J		A202K4C_M

① The listed ampere ratings are based on a maximum load voltage of 480V for tungsten lamp applications and 600V for ballasts or mercury vapor type applications.

② The underscore (_) indicates missing Code letter for Coil Selection — see Table 37-51. Example: Magnet coils with 120/110V coils — change 8th character to A. ECL12C1A3B.

③ Power fuses are not included.

Table 37-50. Class ECL14 & ECL15 — Combination Lighting Contactor — Thermal Magnetic Circuit Breaker

Max. Amp Rating ④	No. of Poles	Continuous Ampere Rating @ 40°C	Type 1 General Purpose		Type 3R Rainproof		Type 4X Watertight & Dust-Tight SS		Type 7/9 Hazardous Location		Type 12 Dust-Tight Industrial		Component Contactor (Open)
			Catalog Number ⑤	Price U.S. \$	Catalog Number ⑤	Price U.S. \$	Catalog Number ⑤	Price U.S. \$	Catalog Number ⑤	Price U.S. \$	Catalog Number ⑤	Price U.S. \$	Catalog Number ⑤
Electrically Held — Class ECL14													
30	3	30	ECL14C1_3E		ECL14C2_3E		ECL14C4_3E		ECL14C6_3E		ECL14C8_3E		CN35DN3_B
60		60	ECL14D1_3F		ECL14D2_3F		ECL14D4_3F		ECL14D6_3F		ECL14D8_3F		CN35GN3_B
100		100	ECL14E1_3G		ECL14E2_3G		ECL14E4_3G		ECL14E6_3G		ECL14E8_3G		CN35KN3_
200	3	200	ECL14F1_3H		ECL14F2_3H		ECL14F4_3H		ECL14F6_3H		ECL14F8_3H		CN35NN3_
300		300	ECL14G1_3J		ECL14G2_3J		ECL14G4_3J		ECL14G6_3J		ECL14G8_3J		CN35SN3_
400		400	ECL14H1_3K		ECL14H2_3K		ECL14H4_3K		ECL14H6_3K		ECL14H8_3K		CN35TN3_
Magnetically Latched — Class ECL15													
30	3	30	ECL15C1_3E		ECL15C2_3E		ECL15C4_3E		ECL15C6_3E		ECL15C8_3E		A202K1C_M
60		60	ECL15D1_3F		ECL15D2_3F		ECL15D4_3F		ECL15D6_3F		ECL15D8_3F		A202K2C_M
100		100	ECL15E1_3G		ECL15E2_3G		ECL15E4_3G		ECL15E6_3G		ECL15E8_3G		A202K3C_M
200		200	ECL15F1_3H		ECL15F2_3H		ECL15F4_3H		ECL15F6_3H		ECL15F8_3H		A202K4C_M

④ The listed ampere ratings are based on a maximum load voltage of 480V for tungsten lamp applications and 600V for ballasts or mercury vapor type applications.

⑤ The underscore (_) indicates missing Code letter for Coil Selection — see Table 37-51. Example: Magnet coils with 120/110V coils — change 8th character to A. ECL12C1A3B.

Table 37-51. Coil Voltage

Rating	Code Letter	Rating	Code Letter	Rating	Code Letter
120V 60 Hz	A	240V 60 Hz	B	480V 60 Hz	C
208V 60 Hz	E	277V 60 Hz	H	600V 60 Hz	D

Additional Common Modifications are available for outside lighting for ballfields, parks, etc.:

- E7 — Service Entrance
- E5 — Enclosure with pole mounting brackets
- P70 — Photocell
- T1 - T25 — Timers

See PG03300001E for details.

Note: The Catalog Numbers listed in the Type 4X column are for Type 4X 304-Grade Stainless Steel, as indicated by the seventh digit 4. Example: ECL12C4A3B. To order Type 4X 316-Grade Stainless Steel, change that digit to 9. To order Type 4 Painted Steel, change that digit to 3. To order Nonmetallic, change that digit to 5. For details on these Alternate Enclosures, see PG03300001E.

- Accessories —
- Magnetically Held Pages 37-20
- Cover Control Page 37-22
- Dimensions PG03300001E
- Accessories —
- Electrically Held PG03300001E
- Modifications Page 37-33
- Discount Symbol 1CD-1C

Wiring Diagrams

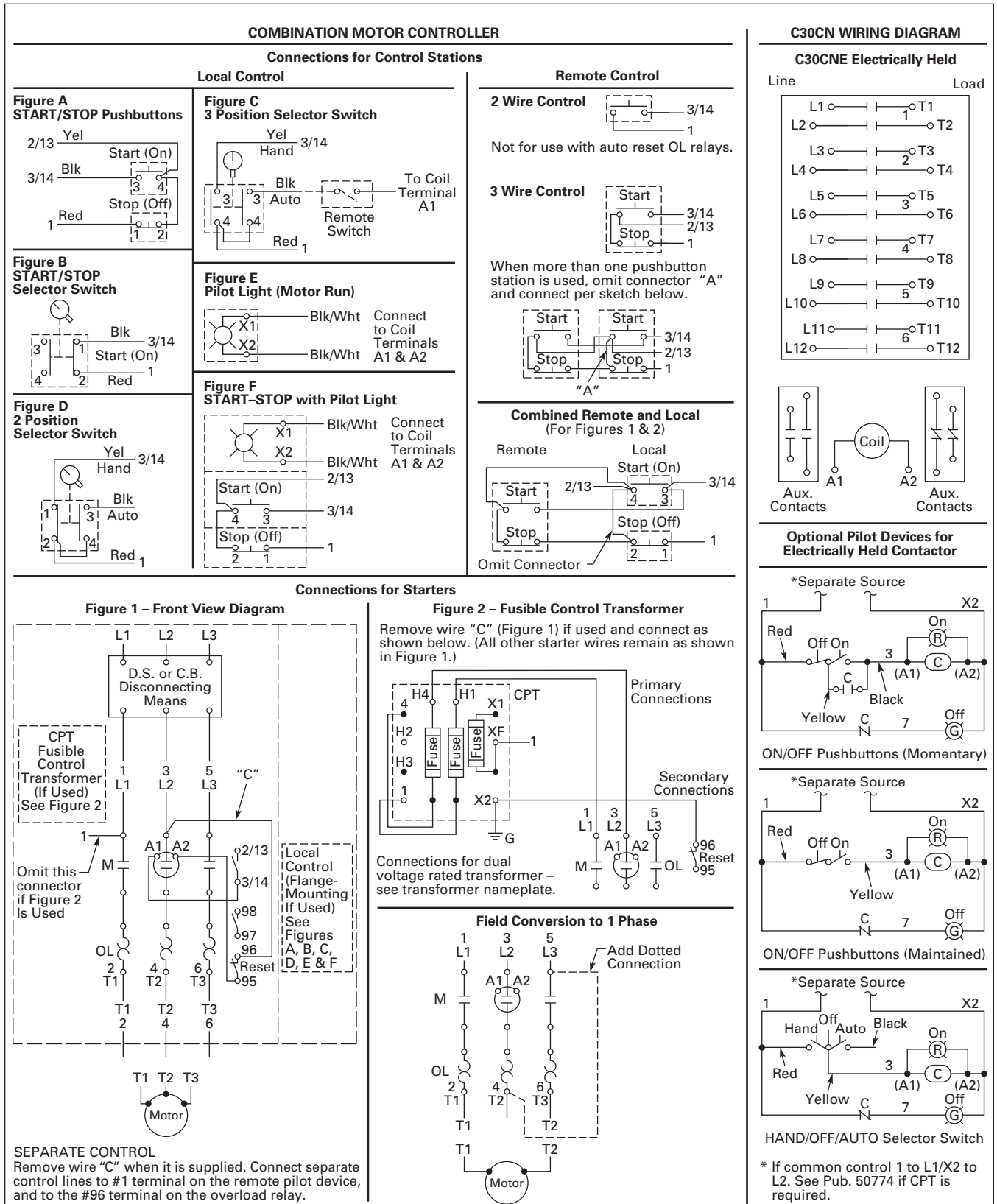

Figure 37-11. Typical Wiring Diagram — C30CN

Wiring Diagrams

37

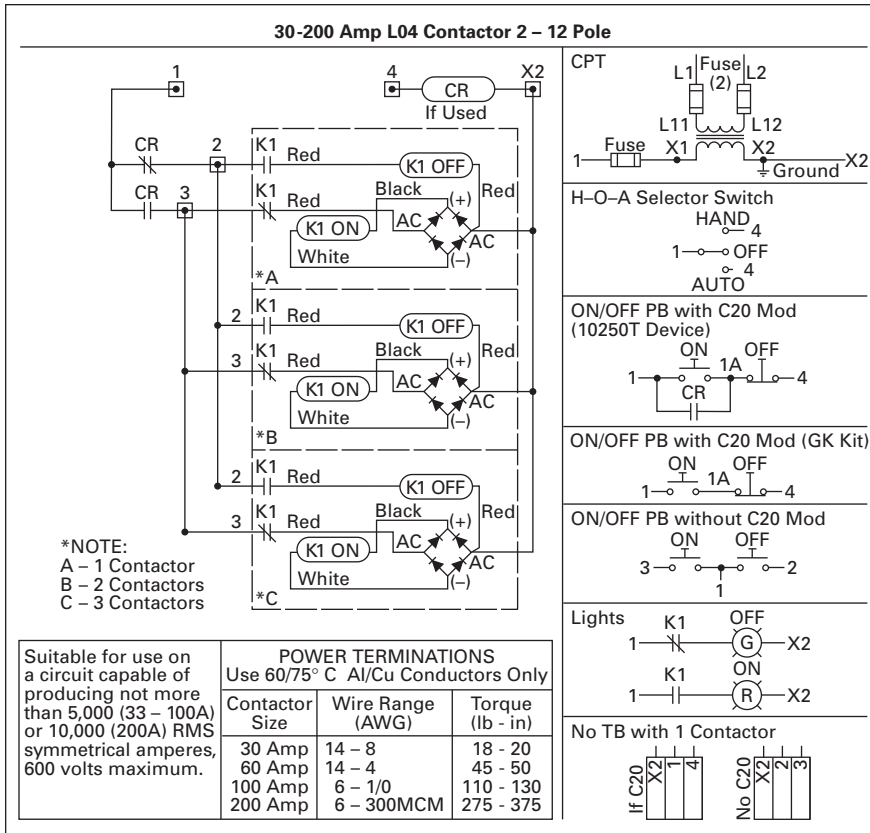

Figure 37-12. Typical Wiring Diagram — Magnetically Latched

Wiring Diagrams

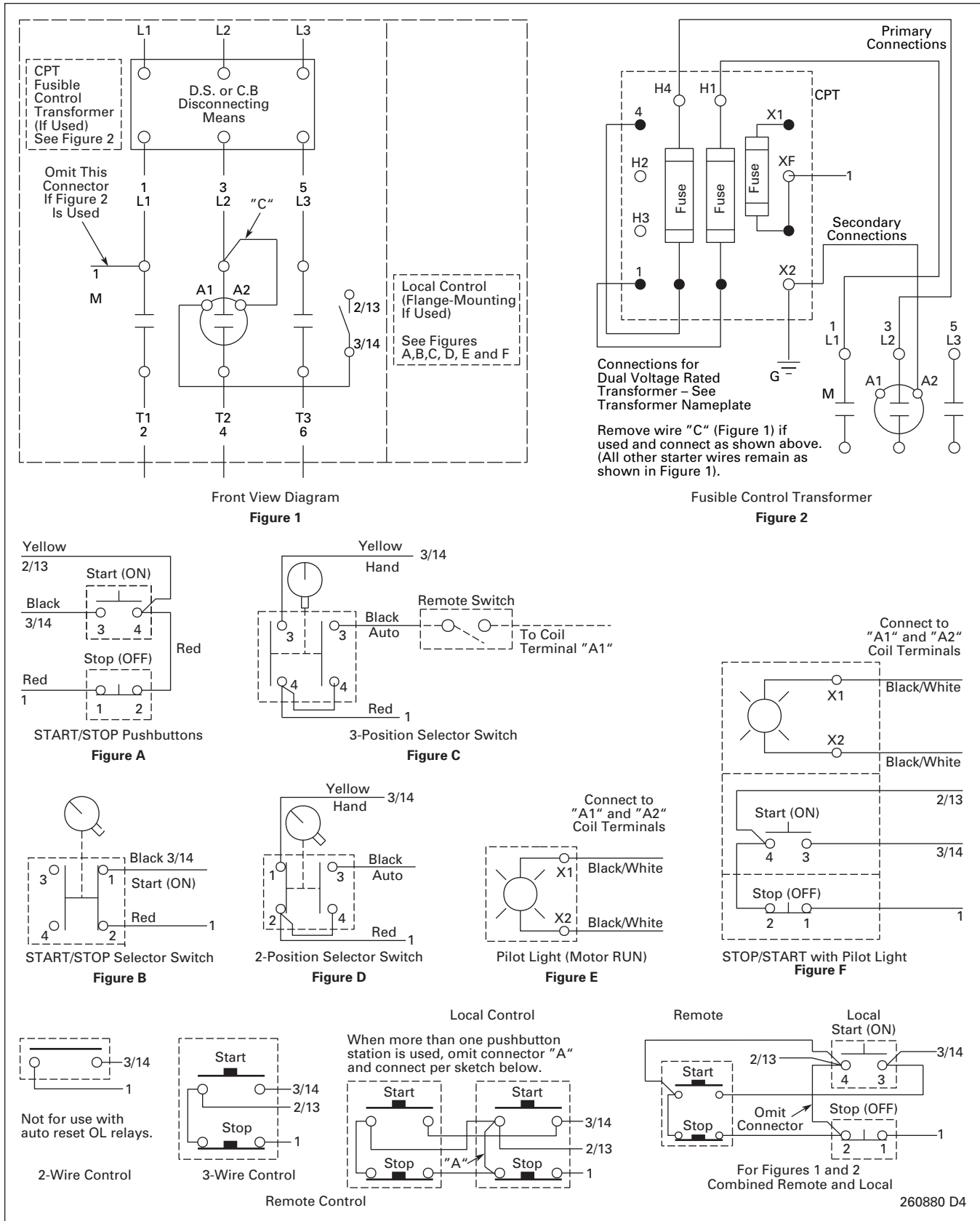

Figure 37-13. Electrically Held Combination Contactors — CN35

Wiring Diagrams

37

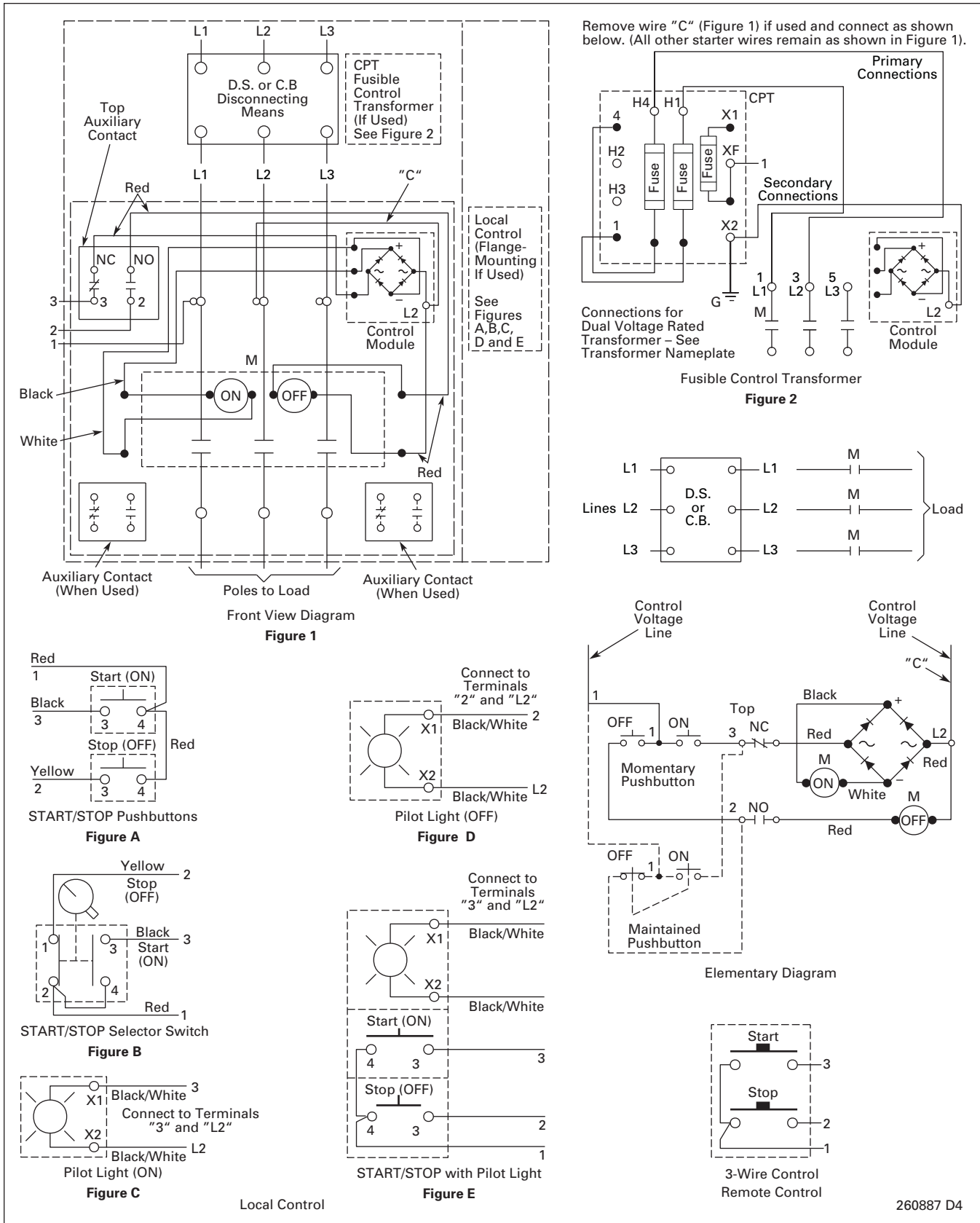

Figure 37-14. Magnetically Latched Combination Contactors

260887 D4

Modification Codes

Modification Codes

Table 37-52. A — Ammeters, Auxiliary Contacts, Accelerating Relays, Autotransformers

Modification	Catalog Number Suffix	Description	
Ammeter ①	A1	Panel Type Wired to Current Transformer in Line 1, Type 1, 12	
		Panel Type Wired to Current Transformer in Line 1, Type 3R, 4X	
	A2	Panel Type, Selector Switch and 3 Current Transformers Wired to Ammeter via Switch, Type 1, 12	
		Panel Type, Selector Switch and 3 Current Transformers Wired to Ammeter via Switch, Type 3R, 4X	
	A3	Miniature (Single-Phase), Type 1, 12	
	A4	Miniature with Selector Switch, Type 1, 12	
	A5	Switchboard (Single-Phase), Type 1, 12	
		Switchboard (Single-Phase), Type 3R, 4X	
	A6	Switchboard with Selector Switch, Type 1, 12	
		Switchboard with Selector Switch, Type 3R, 4X	
	A7	3-Panel Type (Single-Phase), Type 1, 12	
		3-Panel Type (Single-Phase), Type 3R, 4X	
A10	3 Miniature (Single-Phase), Type 1, 3R, 4X, 12		
A11	3 Switchboard Type (Single-Phase), Type 1, 12		
	3 Switchboard Type (Single-Phase), Type 3R, 4X		
A12	Ammeter Order by Description, Type 1, 3R, 4X, 12		
Auto-transformers	A8	hp Rating selection, see P03300001E	
	A9	Order by Description	
Top Mounted Auxiliary Contacts ②③ (Unwired)	A13	1NO	
	A14	1NC	
	A15	1NO-1NC	
	A16	2NO	
	A17	2NC	
	A18	2NO-1NC	
	A19	1NO-2NC	
	A20	3NO	
	A21	3NC	
	A22	3NO-1NC	
NEMA Sizes 00 – 2 only (Unwired)	A23	2NO-2NC	
	A24	1NO-3NC	
	A25	4NO	
	A26	4NC	
	IEC Sizes B – L Only (Unwired) XT Series	A27	1NO
		A28	1NC
A29		1NO-1NC	
A30		2NO	
A31		2NC	
A32		2NO-1NC	
A33		1NO-2NC	
A34		3NO	
Side Mounted Auxiliary Contacts ③④	A27	1NO	
	A28	1NC	
	A29	1NO-1NC	
	A30	2NO	
	A31	2NC	
	A32	2NO-1NC	
	A33	1NO-2NC	
A34	3NO		

Table 37-52. A — Ammeters, Auxiliary Contacts, Accelerating Relays, Autotransformers (Continued)

Modification	Catalog Number Suffix	Description
Side Mounted Auxiliary Contacts, continued ③④	A35	3NC
	A36	3NO-1NC
	A37	2NO-2NC
	A38	1NO-3NC
	A39	4NO
Auxiliary Contacts ③	A40	4NC
	A42	Contacts Mounted on Operating Mechanism of Disconnect Switch, 1NO-1NC
	A43	Contacts Mounted on Operating Mechanism of Disconnect Switch, 2NO-2NC
Accelerating Relay	A44	With Auxiliary Contact Omitted
	A46	For 2-Speed
	A47	2NO/2NC 24V DC Auxiliary Relay — <i>IT</i> . Only

- ① Oversize enclosure will be provided for *IT*. Starters.
- ② Top mounted auxiliary contacts cannot be added to contactors in Box 1 (Type 1).
- ③ Not available for *IT*. Starters.
- ④ Available on *XT* Starters for 40A and greater only.

Table 37-53. B — Breaker Modifications, Backspin Timer, Undervoltage Release, Bell Alarm, Bus Choke

Modification	Catalog Number Suffix	Description
Breaker	B1	1NO-1NC Auxiliary Contact on Breaker
	B2	2NO-2NC Auxiliary Contacts on Breaker
	B3	Shunt Trip on Circuit Breaker — 48 – 127V AC or DC
	B4	Shunt Trip on Circuit Breaker — 9 – 24V AC or DC
	B5	Shunt Trip on Circuit Breaker — 208 – 380V AC
	B6	Shunt Trip on Circuit Breaker — 415 – 600V AC or 220 – 250V DC
	B8	Undervoltage Release for Breaker
	B9	Current Limiter Mounted to Breaker
	B10	Breaker — Order by Description
	B11	Thermal Magnetic Breaker
	Backspin Timer	B12
Undervoltage Release	B13	Undervoltage Release for Circuit Breaker — 208 – 240V AC
	B14	Undervoltage Release for Circuit Breaker — 380 – 480V AC
	B15	Undervoltage Release for Circuit Breaker — 525 – 600V AC
Bell Alarm	B16	Bell Alarm for Circuit Breaker
Bus Choke (MVX)	B20	DC Bus Choke, Open Core and Coil ⑤

⑤ A DC bus choke may be used in place of an AC line reactor for line harmonic current reduction and for power source exceeding 500 kVA. The DC bus choke will not provide any protection for line voltage unbalance or transients.

Modification Codes

Table 37-54. C — Control Power Transformer, *IT*. Power Supplies, Control Relays, Cover Control (not elsewhere defined), Current Transformers, Compelling Relay, Control Wiring, Control Circuit Breaker, Separate Control, Customer-Supplied Components, Custom for Advantage, Contactors, Counter, E-Stop Relay, DC/AC Interface, Separate Source Disconnect, Bypass Contactors

Modification	Catalog Number Suffix	Description
Control Power Transformers Make sure 8th character specifies primary/secondary voltage.	C1	Standard Size Control Transformer, 120V/60 Hz, 110V/50 Hz Secondary with 2 Primary and 1 Secondary Fuse
	C2	Standard Size Control Transformer, 24V/60 Hz Secondary with 2 Primary and 1 Secondary Fuse
	C42	50 VA Extra Capacity CPT 120V/60 Hz, 110V/50 Hz with 2 Primary and 1 Secondary
	C3	100 VA Extra Capacity CPT, 120V/60 Hz, 110V/50 Hz Secondary with 2 Primary and 1 Secondary Fuse
	C4	100 VA Extra Capacity CPT, 24V/60 Hz Secondary with 2 Primary and 1 Secondary Fuse
	C5	200 VA Extra Capacity CPT, 120V/60 Hz, 110V/50 Hz Secondary with 2 Primary and 1 Secondary Fuse
	C6	200 VA Extra Capacity CPT, 24V/60 Hz Secondary with 2 Primary and 1 Secondary Fuse
	C7	300 VA Extra Capacity CPT, 120V/60 Hz, 110V/50 Hz Secondary with 2 Primary and 1 Secondary Fuse
	C8	400 VA Extra Capacity CPT, 120V/60 Hz, 110V/50 Hz Secondary with 2 Primary and 1 Secondary Fuse
	C9	1 kVA Extra Capacity CPT, 120V/60 Hz, 110V/50 Hz Secondary with 2 Primary and 1 Secondary Fuse
	C10	2 kVA Extra Capacity CPT, 120V/60 Hz, 110V/50 Hz Secondary with 2 Primary and 1 Secondary Fuse
	C11	Control Transformer — Order by Description
	C34	CPT with Power Supply for <i>IT</i> . or <i>XT</i>
Power Supplies (<i>IT</i> . and <i>XT</i> Only)	C27	Separate Control 120V AC to 24V DC
	C28	Power Supply with Extra Capacity — Order by Description
Control Relays	C12	4-Pole Interposing Relay, 600V (2NO/2NC)
	C13	Run Relay, 24V DC (MVX)
	C14 ①	4-Pole, Unwired, A600 Rtg. — 2NO-2NC
	C15 ①	8-Pole, Unwired, A600 Rtg. — 4NO-4NC
	C16	Control Relay — Order by Description
	C18 ①②	3-Wire Control Module (C30 Lighting)
	C20 ①②	2-Wire Control Relay for Mechanical/Magnetic Lighting Contactors
Cover Control	C17 ①	Convert Position 7 to E30 Type Cover Control
	C19 ①	Lock-Off Attachment Added on Cover Control
	C29	Change to E22 (22 mm) Cover Controls

① Not available for *IT*. Starters.

② Not available for *XT* Starters.

Table 37-54. C — Control Power Transformer, *IT*. Power Supplies, Control Relays, Cover Control (not elsewhere defined), Current Transformers, Compelling Relay, Control Wiring, Control Circuit Breaker, Separate Control, Customer-Supplied Components, Custom for Advantage, Contactors, Counter, E-Stop Relay, DC/AC Interface, Separate Source Disconnect, Bypass Contactors (Continued)

Modification	Catalog Number Suffix	Description
Current Transformer(s)	C21	In Phase 1
	C22	In Phases 1 and 2
	C23	In 3 Phases
Compelling Relay	C25 ③	—
Control Wiring	C26	Omit Control Wiring
	C30 ③	With Separate Control Wiring and Two 250V Fuses in Holder
	C31 ③	With Common Control Wiring and Two 600V (Class C) Fuses in Holder
	C33	Control Wiring Type — Order by Description
Control Circuit Breaker	C32 ③	Order by Description
Separate Control	C35	Wired for Separate Control (Reduced Voltage)
Customer Supplied Components	C36	Customer Supplied Components to Be Installed
	C37	Customer Supplied Wiring Diagram to Use
Custom for Advantage	C39	Advantage+ Starter Supplied
Contactors/Starter	C40 ③	Contactors/Starter — Order by Description
Counter	C41 ③	Operations Counter
E-Stop Relay	C43 ③	E-Stop Relay (DeviceNet)
DC/AC Interface	C44 ③⑤	DC/AC Interface Module
Separate Source Disconnect	C45 ③	IEC Separate Source Disconnect for Control Circuitry
Bypass Contactors for <i>IT</i> ./MVX Starters (MVX: 1/2 to 5 hp Only)	C46/J1	Isolation Contactor
	C46/J2	Output Contactor
	C46/J3	Bypass Contactor
	C46/J4	Isolation/Output/Bypass Contactor
	C46/J5	3-Contactor Bypass Pkg. for MVX ④

③ Not available for *IT*. Starters.

④ Includes CPT, Pilot Lights, Selector Switch, Auxiliary Contacts and Control Relay.

⑤ Not available for *XT* Starters.

Modification Codes

Table 37-55. D — Device Labels, Deceleration Relay, Drain and Breather, Duplex Modifications

Modification	Catalog Number Suffix	Description
Device Labels	D1	(Each Label)
Decel. Relay ①	D2	2-Speed
Drain and Breather (Type 7/9 Enclosure) ①	D5	Drain and Breather
	D6	Drain Only
	D7	Breather Only
Duplex Modifications	D12	Alternator Omitted (Deduct Price)
	D14	START/STOP Pushbuttons — Supplied for Each Motor
	D15	HAND/OFF/AUTO Selector Switch — Supplied for Each Motor
	D16	No. 1 Lead - No. 2 Lead Selector Switch for Manual Selection of Lead Pump (Alternator is Omitted)
	D17	Red RUN Pilot Light — Supplied for Each Motor
	D18	Push-to-Test Red RUN Pilot Light — Supplied for Each Motor
	D19	TEST Pushbutton for Each Motor
	D20	CPT, 120V Secondary, 2 Pri. Fuses & 1 Sec. Fuse — Supplied for Ea. Motor
	D21	CPT w/100VA Extra Capacity, 120V Sec., 2 Pri. Fuses & 1 Sec. Fuse — Supplied for Each Motor
	D22	CPT w/200VA Extra Capacity, 120V Sec., 2 Pri. Fuses & 1 Sec. Fuse — Supplied for Each Motor
	D23	CPT for Duplex — Order by Description
	D24	Add 2 Relays to Modify Controller to Operate w/Single-Pole Pilot Devices
	D25	Add 3 Relays to Modify Controller to Operate w/Single-Pole Pilot Devices
	D26	Green — OFF for each starter
D27	Green — Push-to-Test OFF for ea. starter	

① Not available for *IT* or *XT* Starters.

Table 37-56. E — Enclosure Modifications, Elapsed Time Meter, Duplex Outlet, Enclosure for Starter, Enclosure Clear Cover, Enclosure Material

Modification	Catalog Number Suffix	Description
Enclosure Modifications	E3	Oversize Enclosure
	E4	Enclosure — Order by Description
	E8	Service Entrance Rating w/Ground Bar
	E11	Safety Door Interlock
Elapsed Time Meter	E9	Wired Across Coil, Type 1, 12 Wired Across Coil, Type 3R, 4X
	E10	Elapsed Time Meter — Order by Description
Duplex Outlet	E12	Convenience Duplex Outlet Mounted in Side of Enclosure
Enclosure for Starter ②	E13	Horizontal Combination Starter, Size 0 – 2
	E14	Narrow Combination Starter, Size 0 – 2
Enclosure Clear Cover for <i>XT</i>	E19	Clear Cover for Halyester Enclosure Nonmetallic
Enclosure Material	E20	Convert to 316 Stainless Steel
	E21	Convert from Type 3R to Stainless Steel

② Not available for *IT* or *XT* Starters.

Table 37-57. F — Fuse Clips, Fuse Blocks, Fungus Protection, Fingerproof Covers, EMI Filter

Modification	Catalog Number Suffix	Description
Fuse Clips ④	F1	Change Fuse Clips in Position 8 to Class J
	F2	Change Fuse Clips in Position 8 to Class H & K (30 & 60 Ampere Only)
Fuse Blocks	F4	Power Fuses Included — Order by Description
	F5	30 Ampere Control Circuit Fuseholder (KTK) Mounted on Panel (Unwired), Fuse Not Supplied
	F6	30 Ampere Control Circuit Fuseholder Mounted on Panel (Unwired), FNQR Fuse Supplied
	F7	3-Pole Power Fuseholder Mounted on Front Contactor
	F8	Separate Fusing of Control Power Supply — <i>IT</i> .
	F10	Blown Fuse Indicator (Not for PFC)
	F21	Class CC Fuses
	EMI Filter (MVX)	F22
F23		1-Phase ③

③ The EMI filter is not necessary to meet the CE mark requirements for EMC when installing the MVX in an EC country.

④ Not available for *XT* Starters.

Modification Codes

Table 37-58. G — Ground Fault Relay, Grounding

Modification	Catalog Number Suffix	Description
Ground Fault Relay	G1	Ground Fault Relay (Wired)
	G3	Ground Fault Relay (Unwired)
Grounding	G5	Special Grounding — Order by Description
	G6	Ground Fault Protection Omitted (Advantage)
	G7	Ground Fault Protection and Monitoring Panel

Table 37-59. H — Heater (Space), Heater Packs Installed

Modification	Catalog Number Suffix	Description	
Space Heater	H1	Space Heater and Thermostat	
	H2	Space Heater and NC Interlock	
Install Heater Packs (Freedom Series)	H5	Class 20	
		Class 10	
		/D1 H2001B-3	/D25 H2101B-3
		/D2 H2002B-3	/D26 H2102B-3
		/D3 H2003B-3	/D27 H2103B-3
		/D4 H2004B-3	/D28 H2104B-3
		/D5 H2005B-3	/D29 H2105B-3
		/D6 H2006B-3	/D30 H2106B-3
		/D7 H2007B-3	/D31 H2107B-3
		/D8 H2008B-3	/D32 H2108B-3
		/D9 H2009B-3	/D33 H2109B-3
		/D10 H2010B-3	/D34 H2110B-3
		/D11 H2011B-3	/D35 H2111B-3
		/D12 H2012B-3	/D36 H2112B-3
		/D13 H2013B-3	/D37 H2113B-3
		/D14 H2014B-3	/D38 H2114B-3
		/D15 H2015B-3	/D39 H2115B-3
		/D16 H2016B-3	/D40 H2116B-3
		/D17 H2017B-3	/D41 H2117B-3
		/D18 H2018-3	
		/D19 H2019-3	
		/D20 H2020-3	
		/D21 H2021-3	
		/D22 H2022-3	
/D23 H2023-3			
/D24 H2024-3			

Table 37-60. K — MVX Keypad ^①

Modification	Catalog Number Suffix	Description
Keypad (MVX)	K1	Door-Mounted AFD Keypad (Type 1 and 12)
	K2	Door-Mounted AFD Keypad (Type 3R)
	K3	AFD Copy Keypad (mounted on drive)
	K4	Door-Mounted AFD Copy Keypad (Type 1 and 12)
	K5	Door-Mounted AFD Copy Keypad (Type 3R)

^① See PG03300001E for more MVX Modifications.

Table 37-61. L — Labels, Line and Load Reactors, Lighting Contactors

Modification	Catalog Number Suffix	Description
Carton Label	L10	Customer Marking — Specify
Line Reactors (MVX)	L12	3% Input Line Reactor, 3-Phase, Open Core and Coil ^②
	L13	3% Input Line Reactor, 1-Phase, Open Core and Coil ^②
	L14	5% Input Line Reactor, 3-Phase, Open Core and Coil ^②
	L15	5% Input Line Reactor, 1-Phase, Open Core and Coil ^②
	L16	Line Reactor — Order by Description
	Load Reactors (MVX)	L17
L18		Load Reactor — Order by Description
Lighting Contactors	L21	1 NC Pole
	L22	2 NC Pole
	L23	3 NC Pole
	L24	4 NC Pole
	L25	5 NC Pole
	L26	6 NC Pole
	L27	7 NC Pole
	L28	8 NC Pole
	L29A	3-Wire 120V AC
	L29B	3-Wire 240V AC
	L29C	3-Wire 24V AC
	L29D	3-Wire 24V DC
	L29E	2-Wire 120V AC
L29F	2-Wire 240V AC	
L29G	2-Wire 24V AC	

^② If the power source exceeds 500 kVA, 3% line unbalance, or if transient voltages from power factor capacitor switching events are present, an input line reactor must be used. The input line reactor will also reduce line current harmonics.

^③ The output line DV/DT filter is required when the distance from the drive to the motor exceeds 33 feet (10m). The total cable run should not exceed 165 feet (50m).

Table 37-62. N — Nameplates

Modification	Catalog Number Suffix	Description
Nameplates	N1	Enclosure Nameplates

Modification Codes

Table 37-63. P — Pilot Lights, Pushbuttons, Phase Relays, Potential Transformers, Power Factor Correction Capacitors, Program Timer, Percentage Timer, Photocell

Modification	Catalog Number Suffix	Description
Push-to-Test Pilot Lights	P1	Push-to-Test Pilot Light (Red RUN) Wired to Coil
	P2	Push-to-Test Pilot Light (Green OFF) Wired in Series with Auxiliary Contact
	P3	Combination of P1 and P2 Above
	P4	Push-to-Test Pilot Light (Amber RUN) Wired to Coil
	P49	Push-to-Test Pilot Light (Green RUN)
	P54 ①	Push-to-Test Pilot Light — Red BYPASS (MVX)
	P56 ①	Push-to-Test Pilot Light — Amber INVERTER ENABLE (MVX)
	P57	Push-to-Test Pilot Light — Green STOP
Pushbuttons	P5	EMERGENCY STOP — Mushroom Head
	P6 ①	Pushbutton Omitted
	P7	START/STOP
	P8	ON/OFF
	P9	START
	P10	ON
	P11	OFF
	P12 ①	FORWARD/REVERSE/STOP
	P13 ①	FAST/SLOW/STOP
	P14 ①	FAST/OFF/SLOW
	P15 ①	HIGH/LOW/STOP
	P16 ①	HIGH/LOW
	P17 ①	SLOW/FAST
	P18 ①	Pushbutton with Legend Plate
	P52	UP/STOP/DOWN
P53	OPEN/STOP/CLOSE	
Pilot Lights	P19	With 1 Amber Pilot Light Marked POWER AVAILABLE Wired to Load Side of 2 Fuses or Circuit Breaker
	P20	Pilot Light (Amber RUN) Wired to Coil
	P21 ①	With 1 Red Pilot Light Marked RUN Wired thru NO Auxiliary Contact
	P22 ①	With 1 Push-to-Test Red Light Marked RUN Wired thru NO Auxiliary Contact
	P23	Pilot Light — Red RUN
	P24	Pilot Light — Red ON
	P25	Pilot Light — Green OFF
	P26	Pilot Light — Order by Description
P29	Pilot Light — Red STOP	

① Not available for *IT* Starters.

Table 37-63. P — Pilot Lights, Pushbuttons, Phase Relays, Potential Transformers, Power Factor Correction Capacitors, Program Timer, Percentage Timer, Photocell (Continued)

Modification	Catalog Number Suffix	Description
Pilot Lights (Continued)	P58	Pilot Light — Red BYPASS (MVX)
	P59 ②	Pilot Light — Amber INVERTER ENABLE (MVX)
	P60 ②	Pilot Light — Red INVERTER RUNNING (MVX)
	P61	Pilot Light — Green STOP
	P62 ②	FORWARD/REVERSE Red Pilot Lights
	P63 ②	UP/DOWN Red Pilot Lights
	P64 ②	OPEN/CLOSE Red Pilot Lights
	P65 ②	HIGH/LOW Red Pilot Lights
	P66 ②	FAST/SLOW Red Pilot Lights
	P67	Green RUN Light
P68	LED Bulbs	
P69	Blue OVERLOAD Light	
Illuminated Pushbutton	P27	Illuminated Pushbutton — Order by Description
Phase Loss Relay	P28	Phase Loss Relay
	P36	Phase Loss Protection Omitted (Advantage)
	P37	Extended Phase Loss Trip Time (Advantage)
Phase Reversal Relay	P30	Phase Reversal Relay
Phase Unbalance Relay	P32	Phase Unbalance Relay
Phase Monitoring Relay	P34	Phase Monitoring Relay
Power Factor Correction Capacitors	P38	/F1 20 kVar /F2 25 kVar /F3 30 kVar /F4 35 kVar /F5 40 kVar /F6 45 kVar /F7 50 kVar /F8 60 kVar
		/F9 70 kVar /F10 75 kVar /F11 80 kVar /F12 90 kVar /F13 100 kVar /F14 125 kVar /F15 150 kVar /F16 175 kVar
		/F17 200 kVar /F18 225 kVar /F19 250 kVar /F20 300 kVar /F21 350 kVar /F22 400 kVar
Potential Transformers	P39 ②	Potential Transformer — Wired L1 – L2
	P40 ②	Potential Transformer — Wired L1– L2 and L2 – L3
	P41 ②	Potential Transformer — 3 Phases
Pump Controller	P42	Pump Controller for <i>IT</i> .
Program Timers	P43	15-Minute Program Timer
	P44	24-Hour Program Timer
	P45	7-Day Program Timer with Day Omission Feature
Percentage Timers	P47	15-Minute Percentage Timer
	P48	60-Minute Percentage Timer
Photocell	P70 ②	Photoelectric Receptacle with Photocell

② Not available for *IT* Starters.

Modification Codes

Table 37-64. Q — IQ Products, DN50

Modification	Catalog Number Suffix	Description
IQ Products	Q1	IQ 500
	Q3	IQ 1000
	Q5	IQ 4000
	Q8	With Wponi (Advantage)
	Q9	With WCTLponi (Advantage)
IQ Data Metering Module	Q12 ①	IQ Data Metering Module
	Q14	IQ 220 with Cable
DN50	Q13 ①	DeviceNet Input/Output Module

① Not available for *IT* Starters.

Table 37-65. R — Ramp, Relays, Solid-State Electronic Overload Relays, Resets, Overload Relay Modifications, Reversing, DeviceNet Interface

Modification	Catalog Number Suffix	Description
Ramp	R1	Extended Ramp of <i>IT</i> .
Relay ②	R2	Overvoltage Relay
Fixed Heater Overload Relay ③	R8	C316FNA3C .25 – .40A
	R9	C316FNA3D .40 – .63A
	R10	C316FNA3E .63 – 1.00A
	R11	C316FNA3F 1.00 – 1.40A
	R12	C316FNA3G 1.30 – 1.80A
	R13	C316FNA3H 1.70 – 2.40A
	R14	C316FNA3J 2.20 – 3.10A
	R15	C316FNA3K 2.80 – 4.00A
	R16	C316FNA3L 3.50 – 5.00A
	R17	C316FNA3M 4.50 – 6.50A
	R18	C316FNA3N 6.00 – 8.50A
	R19	C316FNA3P 7.50 – 11.00A
	R20	C316FNA3Q 10.00 – 14.00A
	R21	C316FNA3R 13.00 – 19.00A
	R22	C316FNA3S 18.00 – 24.00A
	R23	C316FNA3T 24.00 – 32.00A
	R24	C316KNA3A 18.00 – 25.00A
	R25	C316KNA3B 22.00 – 32.00A
	R26	C316KNA3C 29.00 – 42.00A
	R27	C316KNA3D 36.00 – 52.00A
	R28	C316KNA3E 45.00 – 63.00A
	R29	C316KNA3F 60.00 – 80.00A
	R30	C316PNA3A 65.00 – 90.00A
	R31	C316PNA3B 80.00 – 100.00A
	R32	C316PNA3C 100.00 – 135.00A
	R33	C316PNA3D 110.00 – 150.00A
	R34	C316PNA3E 130.00 – 175.00A
	R35	C316PNA3F 150.00 – 200.00A
	R36	C316SNA3A 130.00 – 185.00A
	R37	C316SNA3B 165.00 – 235.00A
	R38	C316SNA3C 220.00 – 310.00A
	R39	C316SNA3D 285.00 – 400.00A
	R40	C316UNA3A 355.00 – 500.00A
	R41	C316UNA3B 465.00 – 650.00A
R42	C316UNA3C 610.00 – 850.00A	

② Not available for *IT* Starters.

③ Not available for *XT* Starters.

Table 37-65. R — Ramp, Relays, Solid-State Electronic Overload Relays, Resets, Overload Relay Modifications, Reversing, DeviceNet Interface (Continued)

Modification	Catalog Number Suffix	Description	
Fixed Heater Overload Relay, continued ③	R43	Fixed Heater Overload Relay — Order by Description	
	R55	C316FNA3F w/Current Transformer 60.00 – 84.00 FLA	
	R56	C316FNA3G w/Current Transformer 78.00 – 108.00 FLA	
	R57	C316FNA3H w/Current Transformer 102.00 – 144.00 FLA	
	R58	C316FNA3J w/Current Transformer 132.00 – 186.00 FLA	
	R59	C316FNA3K w/Current Transformer 168.00 – 240.00 FLA	
	R60	C316FNA3L w/Current Transformer 210.00 – 310.00 FLA	
Solid-State Electronic Overload Relay ⑤	IEC Frame	NEMA Size Full Load Current Adjustment Range (A) 3-Phase Automatic/Manual Reset Class 5/10/20/30	
	Catalog Number Suffix ⑥		R61_
	B & C	00 0.1 – 0.5 0.4 – 2.0 1.0 – 5.0 1.6 – 8.0	A B C D
	C & D	0 & 1 0.1 – 0.5 0.4 – 2.0 1.0 – 5.0 1.6 – 8.0 6.4 – 32	A B C D E
	D	2 9 – 45	F
		3 15 – 75	G
	F & G	22 – 110	H
	G	4 30 – 150	J
	N/A	5 96 – 300	C
	N/A	6 192 – 600	C
	Resets ④	R5	Change External Reset to Internal Reset — Hole Covered with Plug
		R6	Internal Reset — No Hole Plug
		R44	Manual Reset Only on Overload Relay
R45		Auto Reset Only on Overload Relay	
R47		Internal Trip Indicator — No External Reset	
R48		External Reset with External Trip Indicator	
R49		External Reset with Bell Alarm	
R71		N3R Reset Boot Added (Type 1/12 Only)	
Reversing ④		R54	Reversing Contactor/Starter
Overload Relay Mods	R53	Anti Plug-In	
	R61	C395 DNA DeviceNet Module	
	R62	C395 Bell Alarm	
	R63	C395 Load Module	
DeviceNet Interface	R64	C395 Program Key	
	R69	DeviceNet Interface	
	R65	Standard Reset for DeviceNet	
	R66	Lighted Reset for DeviceNet	
	R67	Trip Indicator for DeviceNet	
	R68	DeviceNet Communication Interface (MVX)	

④ Not available for *IT*, or *XT* Starters.

⑤ Features:

- Self-Powered
- Phase Loss Protection
- Current Adjustment Knob
- ± 1% Repeat Accuracy
- 1NO and 1NC Isolated Contacts

⑥ Complete Modification Code includes overload range. Example R61/C.

Modification Codes

Table 37-66. S — System Voltage, Selector Switches, Suppressor, Incomplete Sequence Protection, Single-Phase Jumper, Surge Capacitor, Speed Potentiometer

Modification	Catalog Number Suffix	Description	
System Voltage Selection	S1	System Voltage Selection for Internal Components	
		/H1 208V 60 Hz	
		/H2 240V 60 Hz	
		/H3 277V 60 Hz, 1-Ph	
		/H4 480V 60 Hz	
		/H5 600V 60 Hz	
		/H6 796V 60 Hz	
		/H7 220V 50 Hz	
		/H8 380V 50 Hz	
		/H9 415V 50 Hz	
		/H10 550V 50 Hz	
		/H11 660V 50 Hz	
		/H12 380V 60 Hz	
		/H13 1500V 60 Hz	
	S2	System Voltage Selection — Specify on Order	
Selector Switches ^①	S3	HAND/OFF/AUTO	
	S4	HAND/AUTO	
	S5	HAND/OFF/AUTO Selector Switch with 1 Red RUN Pilot Light	
	S6	RUN/OFF/AUTO	
	S7	AUTO/OFF/TEST	
	S8	AUTO/OFF/TEST Selector Switch with 1 Red RUN Pilot Light	
	S9	AUTO/OFF/TEST Selector Switch with 1 Red RUN Pilot Light and 1 Green Pilot Light	
	S10	OFF/AUTO	
	S11	START/STOP	
	S12	OFF/ON	
	S13 ^②	HIGH/LOW	
	S14 ^②	FAST/OFF/SLOW	
	S15 ^②	SLOW/FAST	
	S16 ^②	FORWARD/REVERSE	
	S17 ^②	HIGH/OFF/LOW	
	S18 ^②	HIGH/LOW/OFF/AUTO	
	S21	HAND/OFF/AUTO Spring Return from Left	
	S38 ^②	INVERTER/OFF/BYPASS (MVX)	
	S41 ^②	OPEN/OFF/CLOSE	
	S42 ^②	FORWARD/OFF/REVERSE	
S43 ^②	FAST/OFF/SLOW/AUTO		
S19 ^②	Selector Switch Omitted (Pump Panels Only)		
S40	Selector Switch — Order by Description		
Suppressor	S24 ^②	Transient Suppressor Mounted on Magnet Coil	
Surge Suppression	S20	MOV (<i>IT</i>)	
Sequence Timer	S26 ^②	Sequence Timer (Pump Panels)	
Sequence Protection	S27 ^②	Incomplete Sequence Protection	
Pump	S28	480V BP9000 Pump	
Single Phase ^②	S29	Convert Contactor or Starter from Three-Phase to Single-Phase — Install Jumper	
		S30	Single-Phase Rev. 120V
		S31	Single-Phase Rev. 240V
Surge Capacitor	S37 ^②	Surge Capacitor Wired to Disconnect Line Side	
Speed Potentiometer	S39 ^②	Speed Potentiometer (MVX)	

^① When using 3-position selector switch with magnetic lighting contactor, mod **C20** must also be used (ECL04, ECL13, ECL15).

^② Not available for *IT* Starters.

Table 37-67. T — Timers, Time Delay Relays, Terminal Blocks, Terminal Points, Ring Lug Connections

Modification	Catalog Number Suffix	Description	
Timers	T1 ^③	Pneumatic Timer Installed on Contactor, Unwired, 30 Sec. Max.	
	T2 ^③	Pneumatic Timer Installed on Contactor, Unwired, 180 Sec. Max.	
	T3	Pneumatic Timer Mounted in Enclosure, Unwired, 180 Sec. Max.	
	T4	Solid-State ON Delay Timer (1 – 30 sec)	
	T5	Solid-State ON Delay Timer (30 – 300 sec)	
	T25	Timer — Order by Description	
Time Delay Relays	T6	Time Delay Relay, 3 Minutes Maximum, Unwired, ON DELAY	
	T7	Time Delay Relay, 3 Minutes Maximum, Unwired, OFF DELAY	
	T8	Time Delay Low Voltage Release Relay	
Terminal Blocks	T9	With 1 Single Circuit Terminal Block, Unwired	
	T10	With 2 Single Circuit Terminal Block, Unwired	
	T24 ^③	Power Terminal Block for DeviceNet Overload	
Terminal Points	T11	With 6 Terminal Points, Unwired	
	T12	With 12 Terminal Points, Unwired	
	T13	With 18 Terminal Points, Unwired	
	T14	Terminal Point per Customer Specification, Unwired (Price Each)	
	T15	Terminal Point per Customer Specification, Wired (Price Each)	
	T21 ^③	3 Terminals Mounted Between Contactor and Overload for Power Factor Capacitors — Sizes 0 – 2	
	T22 ^③	3 Terminals Mounted Between Contactor and Overload for Power Factor Capacitors — Sizes 3 – 4	
	T23 ^③	Quick-Connect Terminals Added to DP Contactor/Starter	
	Ring Lug Connections	T16 ^④	Ring Lug Connections on Power Wires
		T17 ^③	Ring Lug Connections on Control Wires
<i>IT/EM</i>	T30	Reset Only	
	T31	STOP with Reset	
	T32	START/STOP with Reset	
	T33A	HAND/OFF/AUTO with Reset 120V AC	
	T33D	HAND/OFF/AUTO with Reset 24V DC	
	T34	ON/OFF	
	T40	Reset Only (DeviceNet)	
	T41	STOP with Reset (DeviceNet)	
	T42	START/STOP with Reset (DeviceNet)	
	T43A	HAND/OFF/AUTO with Reset 120V AC (DeviceNet)	
	T43D	HAND/OFF/AUTO with Reset 24V DC (DeviceNet)	
	T44	ON/OFF	
	T50	Reset Only	
	T51	STOP with Reset	
	T52	FORWARD/REVERSE/STOP with Reset	
	T53A	FORWARD/REVERSE/STOP with Reset 120V AC	
T53D	FORWARD/REVERSE/STOP with Reset 24V DC		
T54	ON/OFF		

^③ Not available for *IT* Starters.

^④ Not available for *XT* Starters.

Modification Codes

Table 37-67. T — Timers, Time Delay Relays, Terminal Blocks, Terminal Points, Ring Lug Connections (Continued)

Modification	Catalog Number Suffix	Description
<i>IT/EM</i> , continued	T60	Reset Only (DeviceNet)
	T61	STOP with Reset (DeviceNet)
	T62	FORWARD/REVERSE/STOP with Reset (DeviceNet)
	T63A	FORWARD/REVERSE/STOP with Reset 120V AC (DeviceNet)
	T63D	FORWARD/REVERSE/STOP with Reset 24V DC (DeviceNet)
	T64	ON/OFF
	T70	Reset Only
	T71	START/STOP with Reset
	T72	HAND/OFF/AUTO – START with Reset
	T73	FORWARD/REVERSE/STOP with Reset
	T74	HAND/OFF/AUTO – FORWARD/REVERSE with Reset
	T75	ON/OFF with Reset
	T76	FAST/SLOW/STOP with Reset
	T77	HAND/OFF/AUTO – FAST/SLOW with Reset

Table 37-68. U — Undervoltage Relay, Time Delay Undervoltage Relay

Modification	Catalog Number Suffix	Description
Undervoltage Relays	U1	Undervoltage Relay, Non-adjustable
	U2	Undervoltage Relay, Adjustable
Time Delay Undervoltage Relays	U4 ^①	Time Delay Undervoltage Relay, Non-adjustable
	U5	Time Delay Undervoltage Relay, Adjustable
Under- and Overvoltage Relay	U7	Under- and Overvoltage Relay

^① Not available for *IT* Starters.

Table 37-69. V — Voltmeter, Varmeter, Vacuum Starter

Modification	Catalog Number Suffix	Description
Voltmeters	V1	1 Panel Type Voltmeter Wired L1 – L2
	V2	Panel Type Voltmeter and Selector Switch Wired to Read Three Line Voltages
	V3 ^②	Miniature Voltmeter Wired L1 – L2
	V4 ^②	Miniature Voltmeter and Selector Switch Wired to Read Three Line Voltages
	V5	Switchboard Type Voltmeter Wired L1 – L2
	V6 ^②	Switchboard Type Voltmeter and Selector Switch Wired to Read Three Line Voltage
	V7	3 Panel Type Voltmeters Wired in Each Phase
	V8 ^②	3 Miniature Voltmeters Wired in Each Phase
	V9	3 Switchboard Type Voltmeters Wired in Each Phase
	V10	Voltmeter — Order by Description
Varmeter ^③	V11	Varmeter
	V12	Varmeter — Order by Description
Vacuum Starter ^③	V13	Vacuum Starter — 1500V Rating

^② Type 1/12 only.

^③ Not available for *XT* Starters.

Table 37-70. W — Wattmeter, Watt-Hour Meter, Wiremarkers, Wiring Diagram

Modification	Catalog Number Suffix	Description
Wattmeter ^④	W1	Wattmeter
	W3	Watt-Hour Meter
Watt-Hour Meter ^④	W5	Watt-Hour Meter with Demand Attachment
	W7	Wiremarkers
Wiremarkers	W8	Wiremarkers — Order per Customer Diagram or Specifications
	W9	Wiremarkers — Order by Description
WYE-Delta hp	W10 ^⑤	See P03300001E
Windows in Enclosure	W11	Enclosure Windows (MVX)
Wiring Diagram	W12	Reduced Copy of Custom Wiring Diagram Laminated on Inside of Door

^④ Type 1/12 only.

^⑤ Not available for *XT* Starters.