

CATALOG NUMBER	CONDUCTOR		DIMENSIONS			COLOR CODE	BURNDY® INSTALLATION TOOLING (# CRIMPS)										DIELESS (# CRIMPS)		STRIP LENGTH	BARREL MARKING INFORMATION
	ALUMINUM CLASS B CONCENTRIC, COMPRESSED, COMPACT, SIW	COPPER CLASS B, C CONCENTRIC, COMPRESSED, COMPACT	B MIN.	L MAX.	O.D.		DIE INFORMATION		MECHANICAL		HYDRAULIC						MECHANICAL	HYDRAULIC		
							DIE INDEX	TYPE	OUR840	MD6	10	9	9	9	8	7				
YS8CAI 4	#8 STR	#8 STR	.59 [15]	1.44 [37]	.30 [8]	BLUE	374	BLUE DIE SET	X8CART (2)	X8CART (2) W374 (1)	--	U8CABT (1)	U8CABT (1)	U8CABT (1)	--	--	MRC840AL (1) MY29-3 (1)	Y81KFT (1) PAT81KFT (1)	3/4"	FIG. NO.1
YS6CAI	#6 STR (.184)	#6 STR (.184)	.72 [18]	1.70 [43]	.34 [9]	GRAY	346 161	GRAY DIESET	X6CART (2) X161 (2)	X6CART (2) W161 (1)	A6CAB (1)	U6CABT (1) U161 (1)	U6CABT (1) U161 (1)	U6CABT (1) U161 (1)	--	--	MRC840AL (1) MY29-3 (1)	Y81KFT (1) PAT81KFT (1) Y644 (1) PAT644 (1)	7/8"	FIG. NO.1
YS4CAI	#4 STR (.232)	#4 STR (.232)	.86 [22]	1.97 [50]	.43 [11]	GREEN	375 162	GREEN DIE SET	X4CART (3)	X6CART (3) W162 (3)	A4CAB (1)	U4CABT (1) U162 (1)	U4CABT (1) U162 (1)	U4CABT (1) U162 (1)	--	--	MRC840AL (2) MY29-3 (1)	Y81KFT (1) PAT81KFT (1) PAT444 (1) PAT644 (1)	1"	FIG. NO.2
YS2CAI	#2 STR (.292)	#2 STR (.292)	1.09 [28]	2.44 [62]	.53 [13]	PINK	348 163 239	PINK DIE SET	X2CART (4) X239 (4)	X2CART (4) W163 (3) W239 (2)	A2CAB (1)	U2CABT (1) U163 (1) U239 (1)	U2CABT (1) U163 (1) U239 (1)	U2CABT (1) U163 (1) U239 (1)	--	--	MRC840AL (2) MY29-3 (2)		1 1/4"	FIG. NO.1
YS1CAI	#1 STR (.332)	#1 STR (.332)	.90 [23]	2.05 [52]	.54 [14]	GOLD	471 163	GOLD DIE SET	X1CART (3)	X1CART (3) W163 (3)	A1CAR (1)	U1CART (1) U163 (1)	U1CART (1) U163 (1)	U1CART (1) U163 (1)	--	--	MRC840AL (2) MY29-3 (2)		1 1/16"	FIG. NO.1
YS25AI	1/0 STR (.373)	1/0 STR (.373)	1.06 [27]	2.37 [60]	.60 [15]	TAN	296 241	TAN DIE SET	X25ART (4) X241 (4)	X25ART (4) W241 (2)	A25AR (1)	U25ART (1) U241 (1)	U25ART (1) U241 (1)	U25ART (1) U241 (1)	C25AR (1) U241 (1)	--	MRC840AL (2) MY29-3 (2)	Y81KFT(1) PAT81KFT(1) Y644(1) PAT644(1) Y444(1) PAT444(1)	1 3/16"	FIG. NO.1
YS26AI	2/0 STR (.418)	2/0 STR (.418)	1.18 [30]	2.61 [66]	.67 [17]	OLIVE	297 245	OLIVE BG DIE SET	X26ART (4) XBG (4) X245 (4)	X26ART (4) WBG (2) W245 (3)	A26AR (2)	U26ART (2) UBG (2) U245 (1)	U26ART (2) UBG (2) U245 (1)	U26ART (2) UBG (2) U245 (1)	C28AR (1)	--	MRC840AL (3) MY29-3 (2)		1 3/8"	FIG. NO.1
YS27AI	3/0 STR (.470)	3/0 STR (.470)	1.31 [33]	2.88 [73]	.76 [19]	RUBY	467 166	RUBY DIE SET	X27ART (4)	X27ART (4) W166 (4)	A27AR (2)	U27ART (2) U166 (2)	U27ART (2) U166 (2)	U27ART (2) U166 (2)	U27AR (1)	--	MRC840AL (3) MY29-3 (2)		1 1/2"	FIG. NO.1
YS28AI	4/0 STR (.528)	4/0 STR (.528)	1.40 [36]	3.06 [78]	.85 [22]	WHITE	298 660	WHITE DIE SET	X28ART (6) X660 (8)	X28ART (6) W660 (3)	A28AR (2)	U28ART (2) U660 (2)	U28ART (2) U660 (2)	U28ART (2) U660 (2)	C28AR (1)	--	MRC840AL (3) MY29-3 (2)		1 5/8"	FIG. NO.1

NOTES:

- MATERIAL: ALUMINUM TUBE.
- FINISH: TIN PLATED.
- CONNECTORS ARE PREFILLED WITH PENETROX™ OXIDE INHIBITOR. REMOVE EXCESS PENETROX™ FROM CONNECOTR AND CONDUCTOR AFTER MAKING CRIMPS.
- UL LISTED AND CSA CERTIFIED WIRE CONNECTORS. RATED 90 C (AL9CU) FOR USE WITH COPPER OR ALUMINUM CONDUCTOR. APPROVAL APPLY TO TIN PLATED CONNECTORS ONLY. YS8CAI IS RATED AL7CU.
- WHEN MULTIPLE CRIMPS ARE REQUIRED PLACE FIRST CRIMP CLOSEST TO CENTER STOP AND MOVE OUT TOWARD END OF SPLICE WITH SUCCESSIVE CRIMPS.
- DIMENSIONS IN BRACKETS [] ARE IN MILLIMETERS ROUNDED OFF TO THE NEAREST MILLIMETER, UNLESS OTHERWISE NOTED, AND ARE FOR REFERENCE ONLY.
- CATALOG #PT65I5 ADAPTOR IS REQUIRED TO USE "U" DIES IN Y45 SERIES TOOLS.
- CATALOG #PUADP-1 ADAPTOR IS REQUIRED TO USE "U" DIES IN Y46 SERIES TOOLS.
- Y35P3 INDENTOR ADAPTOR REQUIRED FOR "Y34PR" TYPE INDENTORS.
- FOR USE BY CUSTOMERS THAT HAVE THIS HYPRESS™. NO NEW HYPRESSES™ ARE BEING PROCESSED.
- ENLARGED BARREL MARKING VIEW.

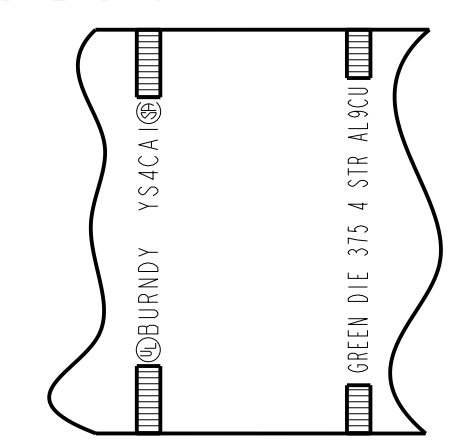
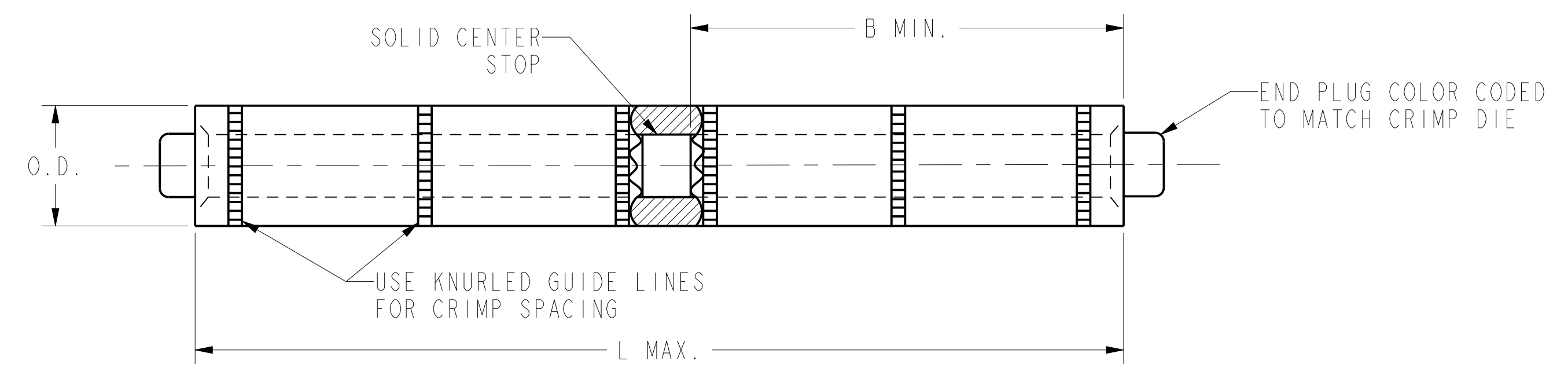

FIG. NO. 2

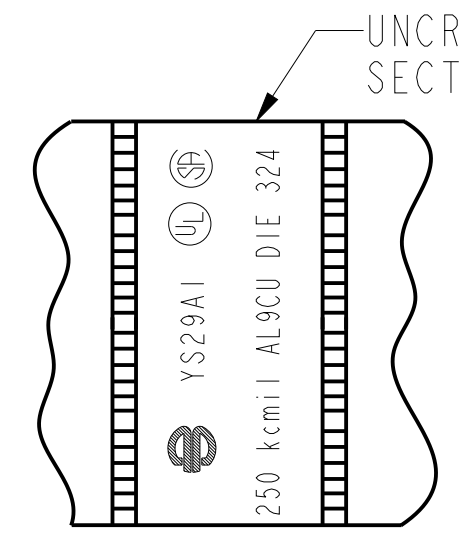

FIG. NO. 1

BARREL MARKING INFORMATION

REV	DATE	DESCRIPTION	ECO	BY	C'H'K.
K	2018-04-12 01:00:00 EDT	UPDATED AS PER MARKUP	48891	YR	VS

CONNECTORS FOR SECONDARY APPLICATION - "YS_AY" (SD026164).
CONNECTORS FOR PRIMARY VOLTAGE FOR ABOVE 5KV "YS_AT" (SC025626).

TO ORDER BURNDY® PRODUCTS CALL
UNITED STATES
1-800-346-4175 (LONDONDERRY, NH)
CANADA:
1-800-361-6975 (QUEBEC)
1-800-387-6487 (ALL OTHER PROVINCES)
FOR PRODUCT INFO: <http://www.burndy.com>

HYLINK™ (ALUMINUM)	
ITEM NO:	N/A
CAT. NO:	YS--A--(TABLE)
DRAWN BY:	ESK 8/24/72
CHECKER:	SFP 8/25/72
DSN APPVL:	D.C.W. 12/12/72
MFG APPVL:	N/A --
GA APPVL:	D VARIO 7/25/95
MKT APPVL:	P WERTHMAN 4/17/95
PROD FAM:	--
PROJECT #:	--
DOCUMENT TYPE:	Sales
REL LEVEL:	Released

SCALE: NTS
DRAWING NO: SD073942
REV: K
SHEET 1 OF 3

REV: PEC200

CATALOG NUMBER	CONDUCTOR SIZE		DIMENSIONS			COLOR CODE	BURNDY® INSTALLATION TOOLING (# CRIMPS)										DIELESS (# CRIMPS)	STRIP LENGTH
	ALUMINUM CLASS B CONCENTRIC, COMPRESSED, COMPACT, SIW	COPPER CLASS B, C CONCENTRIC, COMPRESSED, COMPACT	B MIN.	L MAX.	O.D.		DIE INFORMATION		HYDRAULIC									
							DIE INDEX	TYPE	Y34A Y34B	Y35, Y39 Y750, PAT750	Y46	Y45	Y48BH	Y60				
YS29AI	250 kcmil	250 kcmil	1.46 [37]	3.18 [81]	.92 [23]	RED	324	RED DIE SET	A29AR (2)	U29ART (2)	U29ART (2)	U29ART (2)	C29AR (1)	L29ART (1)	Y81KFT(1) PAT81KFT(1) Y644(1)	1 5/8"		
YS30AI	4/0 AWG CCA DLO (329/22) 300 kcmil	300 kcmil	1.47 [37]	3.20 [81]	1.01 [26]	BLUE	470	BLUE DIE SET	A30AR (2)	U30ART (2)	U30ART (2)	U30ART (2)	C30AR (1)	L30ART (1)	PAT644(1) Y444(1) PAT444(1)	1 3/4"		
YS31AI	250 Kcmil CCA DLO (399/22) 350 kcmil	350 kcmil	1.89 [48]	4.04 [103]	1.11 [28]	BROWN	299	BROWN DIE SET	--	U31ART (2)	U31ART (2)	U31ART (2)	C31ART (1)	--	Y81KFT (3) PAT81KFT (3) PAT444 (1) PAT644 (1)	2 1/8"		
YS32AI	400 kcmil	400 kcmil	2.30 [58]	4.86 [123]	1.19 [30]	GREEN	472	GREEN DIE SET	--	U32ART (4)	U32ART (4)	U32ART (4)	C32AR (2)	L32ART (2)		2 1/2"		
YS34AI	350 Kcmil CCA DLO (551/22) 500 kcmil	500 kcmil	2.38 [60]	5.02 [128]	1.32 [34]	PINK	300	PINK DIE SET	--	U34ART (4)	U34ART (4)	U34ART (4)	C34AR (2)	L34ART (2)		2 5/8"		
YS36AI	500 Kcmil CCA DLO (779/22) 600 kcmil	600 kcmil	2.44 [62]	5.14 [131]	1.44 [37]	BLACK	473	BLACK DIE SET	--	U36ART (4)	U36ART (4)	U36ART (4)	C36AR (2)	L36ART (2)	Y81KFT(4) PAT81KFT(4) Y644(1)	2 7/8"		
YS39AI	700 kcmil-750 kcmil 600 Kcmil CCA DLO (925/22) 900 kcmil COMPACT AL.	--	2.50 [64]	5.26 [134]	1.46 [37]	YELLOW	936	YELLOW DIE SET	--	U39ART-2 (4)	U39ART-2 (4)	U39ART-2 (4)	--	L39ART-2 (2)	PAT644(1) Y444(1) PAT444(1)	2 7/8"		
YS39AMI	700 kcmil-750 kcmil 900 kcmil COMPACT AL.	--	2.63 [67]	5.58 [142]	1.60 [41]	RED	301	RED DIE SET	--	P39ART (4)	S39ART (4)	C39AR (4)	L39ART (4)			2 7/8"		
YS40AI	800 kcmil		2.61 [66]	5.48 [139]	1.65 [42]	GRAY	474	GRAY DIE SET	--	P40ART (4)	S40ART (4)	C40AR (4)	L40ART (4)			3"		
YS42AI	900 kcmil AL WITH U42ART DIE 600-900 Kcmil AL WITH Y644 600 Kcmil CU ONLY WITH Y644		2.47 [63]	5.29 [134]	1.50 [38]	GRAY	303	GRAY DIE SET	--	U42ART (4)	U42ART (4)	U42ART (4)	--	--	Y644(2) PAT644(2) Y444(2) PAT444(2)	2 7/8"		
YS44AI	750 OR 800 Kcmil CCA DLO (1184/22) (1258/22) 1000 kcmil	1000 kcmil	2.84 [72]	5.94 [151]	1.84 [47]	BROWN	302	BROWN DIE SET	--	P44ART (4)	S44ART (4)	C44AR (2)	L44ART (2)		Y644MBH (1) ONLY Y444 (1) Y644 (1)	3 1/8"		

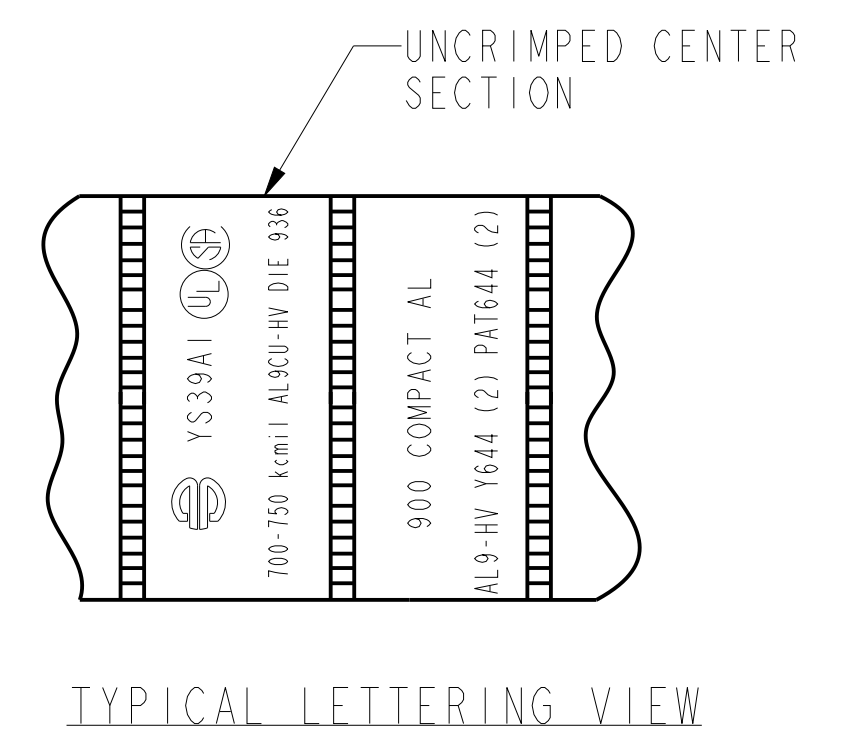

- NOTES:
- MATERIAL: ALUMINUM TUBE.
 - FINISH: TIN PLATED.
 - CONNECTORS ARE PREFILLED WITH PENETROX™ OXIDE INHIBITOR. REMOVE EXCESS PENETROX™ FROM CONNECOTR AND CONDOCOTR AFTER MAKING CRIMPS.
 - UL LISTED AND CSA CERTIFIED WIRE CONNECTORS. RATED 90 C (AL9CU) FOR USE WITH COPPER OR ALUMINUM CONDUCTOR. APPROVAL APPLY TO TIN PLATED CONNECTORS ONLY.
 - WHEN MULTIPLE CRIMPS ARE REQUIRED PLACE FIRST CRIMP CLOSEST TO CENTER STOP AND MOVE OUT TOWARD END OF SPLICE WITH SUCCESSIVE CRIMPS.
 - DIMENSIONS IN BRACKETS [] ARE IN MILLIMETERS ROUNDED OFF TO THE NEAREST MILLIMETER, UNLESS OTHERWISE NOTED, AND ARE FOR REFERENCE ONLY.

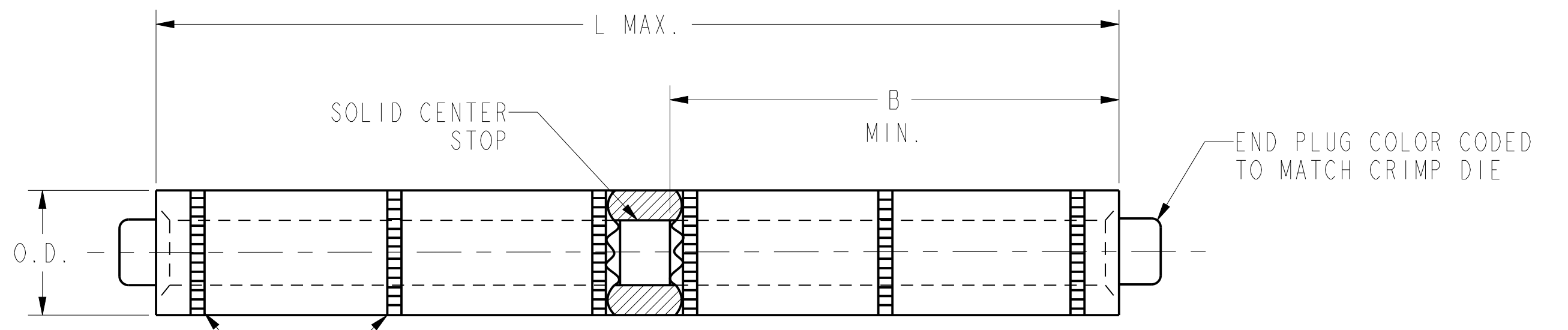

- CATALOG #PT6515 ADAPTOR IS REQUIRED TO USE "U" DIES IN Y45 SERIES TOOLS.
- CATALOG #PUADP-1 ADAPTOR IS REQUIRED TO USE "U" DIES IN Y46 SERIES TOOLS.
- Y35P3 INDENTOR ADAPTOR REQUIRED FOR "Y34PR" TYPE INDENTORS.
- FOR USE BY CUSTOMERS THAT HAVE THIS HYPRESS™. NO NEW HYPRESSES™ ARE BEING PROCESSED.
- UL LISTED WITH DLO COPPER CLAD ALUMINUM CONDUCTOR USING Y644 TOOLS ONLY.
- USE PAT644, Y644, PAT444, OR Y444 TOOLING ONLY WHEN INSTALLING 900 KCMIL COMPACT AL. APPLY 2 CRIMPS.

USE KNURLED GUIDE LINES FOR CRIMP SPACING

CONNECTORS FOR SECONDARY APPLICATION- "YS-AY" (SD26164).
CONNECTORS FOR PRIMARY VOLTAGE FOR ABOVE 5KV "YS-AT" (SC25626).

TO ORDER BURNDY® PRODUCTS CALL		HYLINK™ (ALUMINUM)	
UNITED STATES 1-800-346-4175 (LONDONDERRY, NH)		ITEM NO: N/A	CAT. NO: YS--A--(TABLE)
CANADA: 1-800-361-6975 (QUEBEC) 1-800-387-6487 (ALL OTHER PROVINCES)		DRAWN BY: E.S.K. 8/25/72	CHECKER: S.F.P. 8/25/72
FOR PRODUCT INFO: http://www.burndy.com		DSN APPVL: D.C.W. 12/12/72	MFG APPVL: --
		QC APPVL: D VARIO 7/25/95	MKT APPVL: P WERTHMAN 4/17/95
		PROD FAM: --	SCALE: NTS
		PROJECT #: --	SIZE: D
		DOCUMENT TYPE: Sales	DRAWING NO: SD073942
		REL LEVEL: Released	SHEET 2 OF 3

REV	DATE	DESCRIPTION	ECO	BY	C'H'K.
K	2018-04-12 01:00:00 EDT	UPDATED AS PER MARKUP	48891	YR	VS

REV: PE0200

CATALOG NUMBER	CONDUCTOR		DIMENSIONS			COLOR CODE	BURNDY® INSTALLATION TOOLING (# CRIMPS)						STRIP LENGTH	
	ALUMINUM CLASS B CONCENTRIC, COMPRESSED, COMPACT, SIW	COPPER CLASS B, C CONCENTRIC, COMPRESSED, COMPACT	B MIN.	L MAX.	O.D.		DIE INFORMATION		HYDRAULIC					DIELESS (# CRIMPS)
							DIE INDEX	TYPE	Y46	Y45	Y48BH	Y60		
YS45A1	900 OR 1000 Kcmil CCA DLO (1406/22) (1554/22) 1250 kcmil	1250 kcmil	2.84 [72]	6.21 [158]	1.84 [47]	BROWN	302	BROWN DIE SET	PA44ART (4)	S44ART (4)	C44AR (2)	L44ART (2)	Y644MBH (1) ONLY	3 1/8"
7 YS45A2	1250 kcmil		2.23 [57]	4.67 [119]	1.84 [47]	BROWN	302	BROWN DIE SET	PA44ART (4)	S44ART (4)	C44AR (2)	L44ART (2)	Y644MBH (1) ONLY	3 1/8"
YS46A1	1500 kcmil		3.40 [86]	7.05 [179]	2.26 [57]	BLUE	478	BLUE DIE SET	--	--	C46AR (2)	L46ART (2)	--	3 3/4"
7 YS46A2	1500 kcmil		3.18 [81]	6.57 [167]	2.26 [57]	BLUE	478	BLUE DIE SET	--	--	C46AR (2)	L46ART (2)	--	3 3/4"
YS47A1	1750 kcmil		3.99 [101]	8.31 [211]	2.44 [62]	WHITE	587	WHITE DIE SET	--	--	--	L47ART (2)	--	4 3/8"
YS48A1	2000 kcmil		3.66 [93]	7.58 [193]	2.60 [66]	RED	479	RED DIE SET	--	--	--	L48ART (2)	--	4 1/8"
7 YS483A1	2250 kcmil ALUMINUM ONLY NOT UL LISTED/CSA CERTIFIED		3.66 [93]	7.58 [193]	2.60 [66]	RED	479	RED DIE SET	--	--	--	L48ART (2)	--	4 1/8"

REV	DATE	DESCRIPTION	ECO	BY	C.H.K.
K	2018-04-12 01:00:00 EDT	UPDATED AS PER MARKUP	48891	YR	VS

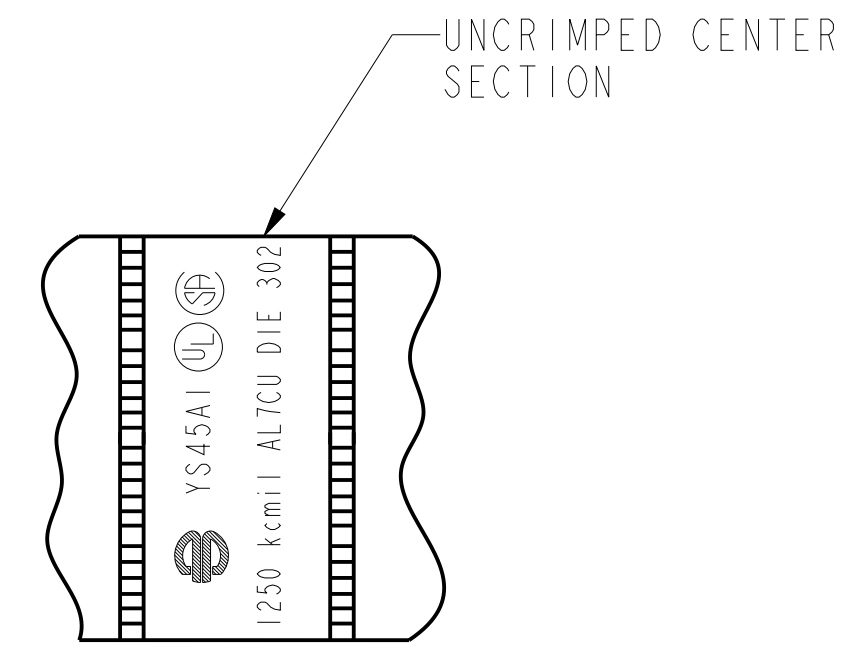

TYPICAL LETTERING VIEW

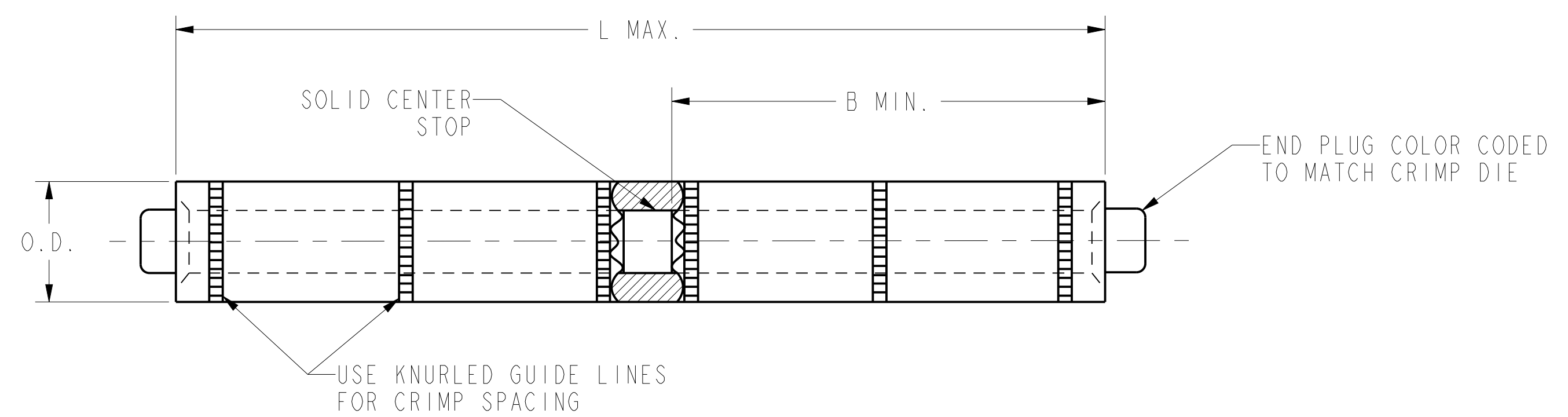

- NOTES:
- MATERIAL: ALUMINUM TUBE.
 - FINISH: TIN PLATED.
 - CONNECTORS ARE PREFILLED WITH PENETROX™ OXIDE INHIBITOR. REMOVE EXCESS PENETROX™ FROM CONNECOTR AND CONDUCTOR AFTER MAKING CRIMPS.
 - UL LISTED AND CSA CERTIFIED WIRE CONNECTORS. RATED 75C (AL7CU) FOR USE WITH COPPER OR ALUMINUM CONDUCTOR. APPROVAL APPLY TO TIN PLATED CONNECTORS ONLY.
 - WHEN MULTIPLE CRIMPS ARE REQUIRED PLACE FIRST CRIMP CLOSEST TO CENTER STOP AND MOVE OUT TOWARD END OF SPLICE WITH SUCCESSIVE CRIMPS.
 - DIMENSIONS IN BRACKETS [] ARE IN MILLIMETERS ROUNDED OFF TO THE NEAREST MILLIMETER, UNLESS OTHERWISE NOTED, AND ARE FOR REFERENCE ONLY.

- CATALOG NUMBERS YS45A2, YS46A2 AND YS483A1 ARE UNPLATED
- CATALOG #PT6515 ADAPTOR IS REQUIRED TO USE "U" DIES IN Y45 SERIES TOOLS.
- CATALOG #PUADP-I ADAPTOR IS REQUIRED TO USE "U" DIES IN Y46 SERIES TOOLS.
- Y35P3 INDENTOR ADAPTOR REQUIRED FOR "Y34PR" TYPE INDENTORS.
- UL LISTED WITH DLO COPPER CLAD ALUMINUM CONDUCTOR USING Y644 TOOLS ONLY.

TO ORDER BURNDY® PRODUCTS CALL		HYLINK™ (ALUMINUM)	
UNITED STATES 1-800-346-4175 (LONDONDERRY, NH)		ITEM NO: N/A	CAT. NO: YS--A--(TABLE)
CANADA: 1-800-361-6975 (QUEBEC) 1-800-387-6487 (ALL OTHER PROVINCES)		DRAWN BY: E.S.K. 8/25/72	CHECKER: S.F.P. 8/25/72
FOR PRODUCT INFO: http://www.burndy.com		DSN APPVL: J.MICHAUD 04/04/06	MFG APPVL: N/A
		QC APPVL: D VARIO 7/25/95	MKT APPVL: P WERTHMAN 4/17/95
		PROD FAM: --	DRAWING NO: SD073942
		PROJECT #: --	SCALE: NTS
		DOCUMENT TYPE: Sales	REV: K
		REL LEVEL: Released	SHEET 3 OF 3

REV: PEC200